

THE SOUKS

Designed by Valori Wells
www.valoriwells.com

Featuring
Mystic
Valori Wells



Finished quilt measures: 60" x 78"

Pattern Level: Confident Beginner













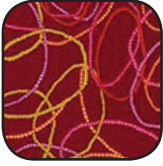

*"I have basic block construction down
and would like to learn a new trick!"*

ROBERTKAUFMAN
F A B R I C S

For questions about this pattern, please email Patterns@RobertKaufman.com.

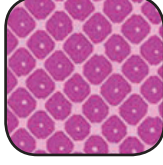
Fabric and Supplies Needed

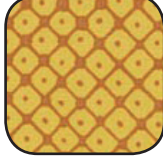
Fabric amounts based on yardage that is 40" wide.

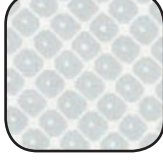
Color	Fabric	Name/SKU	Yardage	Color	Fabric	Name/SKU	Yardage
	A	AVW-15857-316 COASTAL FOG	1-3/4 yard		J	AVW-15857-189 EBONY	1/8 yard
	B	AVW-15856-64 AZURE	1/4 yard		K	AVW-15857-291 CURRY	1/8 yard
	C	AVW-15856-189 EBONY	1/8 yard		L	AVW-15858-64 AZURE	1/8 yard
	D	AVW-15856-281 POMEGRANATE	1/8 yard		M	AVW-15858-78 PEACOCK	1/8 yard
	E	AVW-15856-316 COASTAL FOG	1/8 yard		N	AVW-15858-93 SCARLET	1/8 yard
	F	AVW-15856-291 CURRY	1/8 yard		O	AVW-15858-189 EBONY	1/8 yard
	G	AVW-15857-64 AZURE	1/8 yard		P	AVW-15858-232 WINEBERRY	1/8 yard
	H	AVW-15857-78 PEACOCK	1/8 yard		Q	AVW-15858-291 CURRY	1/8 yard
	I	AVW-15857-116 TOMATO	1/8 yard		R	AVW-15858-316 COASTAL FOG	1/8 yard

Fabric and Supplies Needed

Fabric amounts based on yardage that is 40" wide.

Color	Fabric	Name/SKU	Yardage	Color	Fabric	Name/SKU	Yardage
	S	AVW-15859-78 PEACOCK	1/4 yard		BB	AVW-15860-305 GRAPHITE	1/4 yard
	T	AVW-15859-281 POMEGRANATE	1/4 yard		CC	AVW-15860-316 COASTAL FOG	1/8 yard
	U	AVW-15859-305 GRAPHITE	1/4 yard		DD	K001-1016 BERRY	1/8 yard
	V	AVW-15859-316 COASTAL FOG	1/8 yard		EE	K001-1066 CERISE	1/8 yard
	W	AVW-15859-326 EXTRACT	1/4 yard		FF	K001-1071 CHARCOAL	1/8 yard
	X	AVW-15860-64 AZURE	1/8 yard		GG	K001-1082 COCOA	1/8 yard
	Y	AVW-15860-78 PEACOCK	1/4 yard		HH	K001-1091 CRIMSON	1/8 yard
	Z	AVW-15860-232 WINEBERRY	1/8 yard		II	K001-110 PEONY	1/8 yard
	AA	AVW-15860-281 POMEGRANATE	1/8 yard		JJ	K001-1154 GOLD	1/8 yard





Fabric and Supplies Needed

Fabric amounts based on yardage that is 40" wide.

Color	Fabric	Name/SKU	Yardage	Color	Fabric	Name/SKU	Yardage
	KK	K001-1229 MERINGUE	1/8 yard		TT	K001-194 LAKE	1/8 yard
	LL	K001-1265 ORANGE	1/8 yard		UU	K001-26 CANARY	1/8 yard
	MM	K001-1268 OYSTER	1/8 yard		VV	K001-295 GRAPHITE	1/8 yard
	NN	K001-1314 ROYAL	1/8 yard		WW	K001-32 SURF	1/8 yard
	OO	K001-1333 SILVER	1/8 yard		XX	K001-454 PRUSSIAN	1/8 yard
	PP	K001-1387 WHITE	1/8 yard		YY	K001-456 SHALE	1/8 yard
	QQ	K001-1470 PEWTER	1/8 yard		ZZ	K001-458 STORM	1/8 yard
	RR	K001-1513 SKY	1/8 yard		AAA	K001-481 SANGRIA	1/8 yard
	SS	K001-184 EGGSHELL	1/8 yard		BBB	K001-484 ASTRAL	1/8 yard

Fabric and Supplies Needed

Fabric amounts based on yardage that is 40" wide.

Color	Fabric	Name/SKU	Yardage	Color	Fabric	Name/SKU	Yardage
	CCC	K001-488 DAHLIA	1/8 yard		EEE	K001-497 NIAGARA	1/8 yard
	DDD	K001-494 MALIBU	1/8 yard		FFF	K001-500 TITANIUM	1/8 yard
Copyright 2016, Robert Kaufman For individual use only - Not for resale				You will also need: 4 yards for backing 1/2 yard for binding			

Pattern Notes

- Read through all of the instructions before beginning.
- All of the seam allowances are 1/4" unless otherwise noted.
- Press seam allowances open unless otherwise noted.
- Width of fabric (WOF) is equal to at least 40" wide.
- Right sides together has been abbreviated to RST.
- Remember to measure twice and cut once!

Cutting Instructions

Step 1. The first step for cutting will be to cut rectangles for the larger pieces in each row.

After the rectangle is cut, instructions are given to sub-cut each piece and the row it is in.

The first sub-cut will be a 45° cut, either cutting from top left down, or from bottom left up, depending on the row the piece is used in. Rows 1, 3, 5, 7, and 9 the first cut is from top left down (45° angle cut).

Rows 2, 4, 6, 8, and 10 the first cut is from the bottom left up (45° angle cut).

Refer to cutting illustration. [Figure 1](#).

The second sub-cut is cutting from the opposite end of the rectangle, and if first sub-cut was from top left down, second sub-cut will be from bottom right up (45° angle cut).

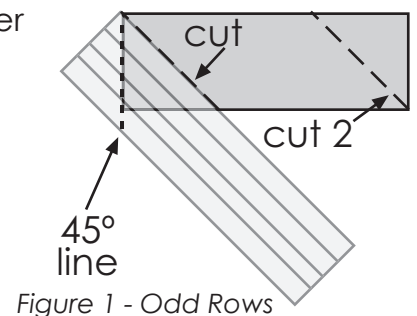

Figure 1 - Odd Rows

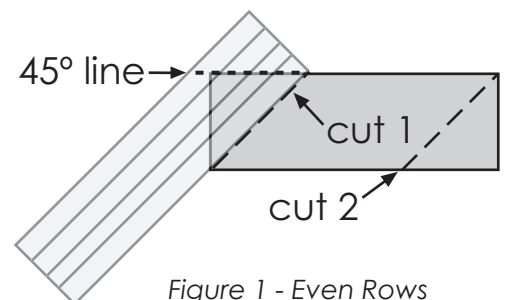

Figure 1 - Even Rows

First sub-cut from bottom left up, the second sub-cut will be from top right down (45° angle cut).

From Fabric B, cut:

- one - 6-1/2" x 17-1/2" Row 4 rectangle,
- one - 3-1/2" x 14-3/4" Row 9 rectangle
- one - 5-1/2" x 5-1/2" square for Row 10.

cut this square once on the diagonal as shown for Row 10.

Figure 2. Note: This is the only cut done this way.

Cut the 6-1/2" x 17-1/2" Row 4 rectangle as shown in Figure 3.

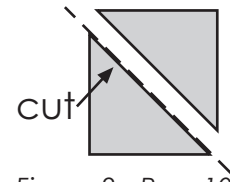

Figure 2 - Row 10

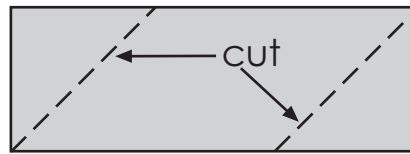

Figure 3

Cut the 3-1/2" x 14-3/4" Row 9 rectangle as shown in Figure 4.



Figure 4

From Fabric A, cut:

- two - 3-1/2" x 11-3/4" Row 2 rectangles,
- one - 5" x 13-3/4" Row 5 rectangle,
- one - 6-1/2" x 14-3/4" Row 6 rectangle,
- one - 4-1/2" x 15-1/4" Row 7 rectangle.

For this fabric and all remaining cuts listed here, cut the rectangles referring to previous cuts, and cutting as either even numbered row, or odd numbered row cutting, as indicated in Figure 1.

From Fabric S, cut:

- one - 4" x 12-1/4" Row 1 rectangle,
- one - 5" x 18-3/4" Row 5 rectangle,
- one - 5-1/2" x 16-3/4" Row 10 rectangle.

From Fabric T, cut:

- one - 4" x 15" Row 1 rectangle,
- one - 6-1/2" x 14-3/4" Row 6 rectangle,
- one - 4-1/2" x 12-3/4" Row 7 rectangle.

From Fabric U, cut:

- one - 4-1/2" x 12-3/4" Row 7 rectangle
- one - 5-1/2" x 13-3/4" Row 10 rectangle.

From Fabric W, cut:

- two - 5" x 13-3/4" Row 3 rectangles,
- one - 3-1/2" x 14-3/4" Row 6 rectangle,

one - 3-1/2" x 11-3/4" Row 8 rectangle.

From Fabric Y, cut:

one - 4" x 12-1/4" Row 1 rectangle,
one - 3-1/2" x 9" Row 9 rectangle.

From Fabric BB, cut:

one - 3-1/2" x 11-3/4" Row 2 rectangle,
one - 6-1/2" x 14-3/4" Row 4 rectangle,
one - 3-1/2" x 11-3/4" Row 8 rectangle.

Step 2.

From Fabric A, cut:

four - 10" x 42" strips. Sew these together into two - 10" x approximately 84" strips. Press. Trim each strip of border fabric to 80-1/2" long.

Step 3.

From all fabrics, cut:

one 1-1/2" x 42" (or width of remaining fabric) strip from each. Cut additional strips as needed.

Next step is to "pair" up your fabrics. Select a dark and a light/or bright and dull for each pair.

Refer to the quilt photo. Pairs will be sewn in sets of two strips, three strips, four strips, and so on, up to eight strips. Do not sew the strips together at this point.

For example: Row 1 uses a set of four strips, a large piece, set of three strips, set of six strips, set of four strips, a large piece, set of four strips, set of eight strips, set of four strips, a large piece, and set of six strips.

There is no right or wrong as to the number of pairs in each row.

Length of strips to cut for each row will be given, and once the strips are sewn into pairs, the odd numbered rows will be cut as before – refer to [Figure 1](#), and even numbered rows will be cut as shown in [Figure 2](#).

The length of the strip allows enough extra to off-set the strip when starting to sew (see [Figure 8](#)) and also at the end of the strips.

For rows 1, 3, 5, 7, and 9:

The first cut is from bottom left up (45° angle).

Note this is opposite from how you cut the angles for the large pieces. [Figure 5](#).

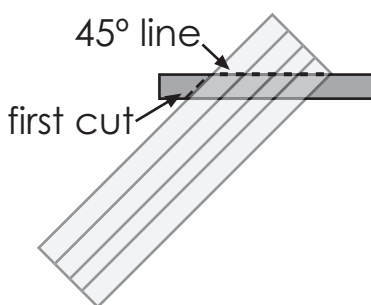

Figure 5

Second cut (cutting the strips to the correct length):

For this cut you line the straight edge of the ruler along the 45° cut, then measure 4 3/4" over and make a second cut (this will be a 45° cut when you remove your ruler). [Figure 6](#).

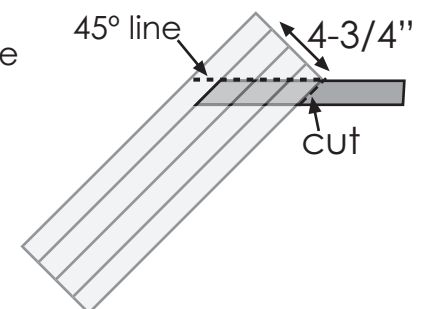

Figure 6

Repeat, cutting the number of strips you need for the pair you are making.

Cutting suggestion: After selecting your two fabrics for the pair, layer the two pieces right sides up, and cut both pieces at the same time. If you are cutting a set of four strips, you will make two cuts and get your four strips, two of each fabric.

Row 1 – After making the 45° cut, measure over 4-3/4" and make the straight cut, and continue cutting the number of strips you need. [Figure 6](#).

Row 3 and Row 5 – After initial cut measure over 6 1/2" and cut.

Row 7 – After initial cut measure over 5" and cut.

Row 9 – After initial cut measure over 4" and cut.

Row 2 – After initial cut measure over 4" and cut [Figure 7](#).

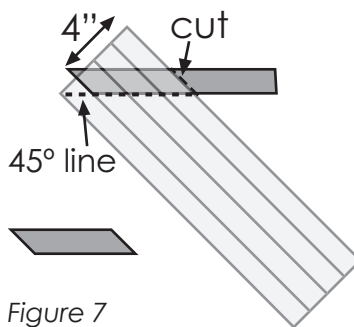

Figure 7

Row 4 and Row 6 – After initial cut measure over 6-3/4" and cut

Row 8 – After initial cut measure over 4" and cut

Row 10 – After initial cut measure over 6" and cut

Sewing Instructions

Step 1. Starting with Row 1 pairs, sew the strips in each pair together.

When starting to sew right sides together, off-set the strip you are sewing on 1/4" as shown in [Figure 8](#).

When the strip set contains the number of strips you want, for example, six strips, press the set carefully, since you are working with bias edges.

The strip set unit will be a bit wider than you need. Refer to the unfinished width of the row the strip set will be going into, and trim the set to that width. For example, Row 1, the unfinished width measurement is 4", so you will trim the strip set as shown in [Figure 9](#).

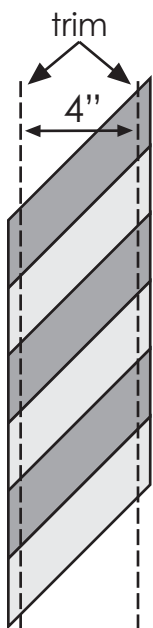

Figure 9

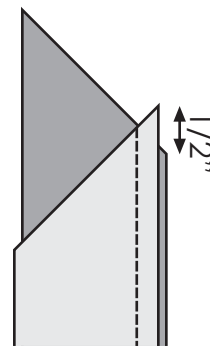

Figure 8

Arrange the Row 1 strip sets with the three large pieces. When you are pleased with your arrangement, sew the row together. Press. Make each row 82 - 84" long. This will give you a little extra when you will be squaring up the top, sewing the rows together, then trimming the bottom of the row. Do not trim the ends until Step 4.

Step 2. Continue making rows, first sewing the pairs, then arranging them with the large pieces for the row you are working on. Then sew the row together. When arranging the second row, lay it beside the first row on your design wall. Do not worry about matching the seams. This is the feature of the random design of this quilt.

Unfinished width of each row that you will need to trim the pair strip sets as shown:

See *Figure 9*.

Row 1	4"
Row 2	3-1/2"
Row 3	5"
Row 4	6-1/2"
Row 5	5"
Row 6	6-1/2"
Row 7	4-1/2"
Row 8	3-1/2"
Row 9	3-1/2"
Row 10	5-1/2"

Step 3. Square up the top of Row 1. *Figure 10*.

Sew Row 1 to one of the border strips.

The bottom of the row should extend a bit beyond the bottom edge of the border.

Figure 11.

If you find it is not long enough, just sew another pair strip set to the bottom of the row. Square up the bottom of Row 1 with the border fabric. *Figure 11*.

Step 4. Square up the top end of Row 2, then sew it to Row 1. Press. Square up the bottom of the row. Continue this process, squaring up the top of each row, then sewing it on to the previous row.

Step 5. After all ten rows have been sewn together, sew the other side border strip to Row 10. Press.

Step 6. Your quilt top is now complete! Baste, quilt, bind and enjoy!

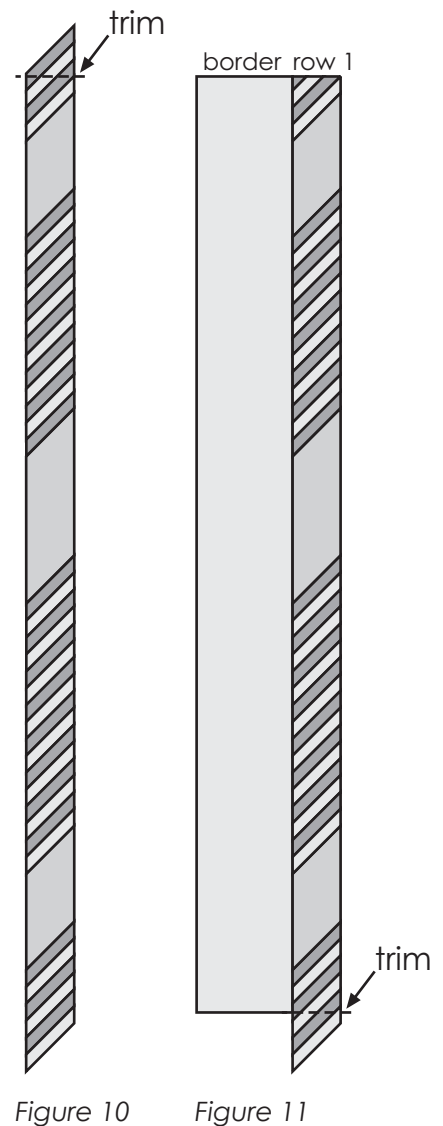
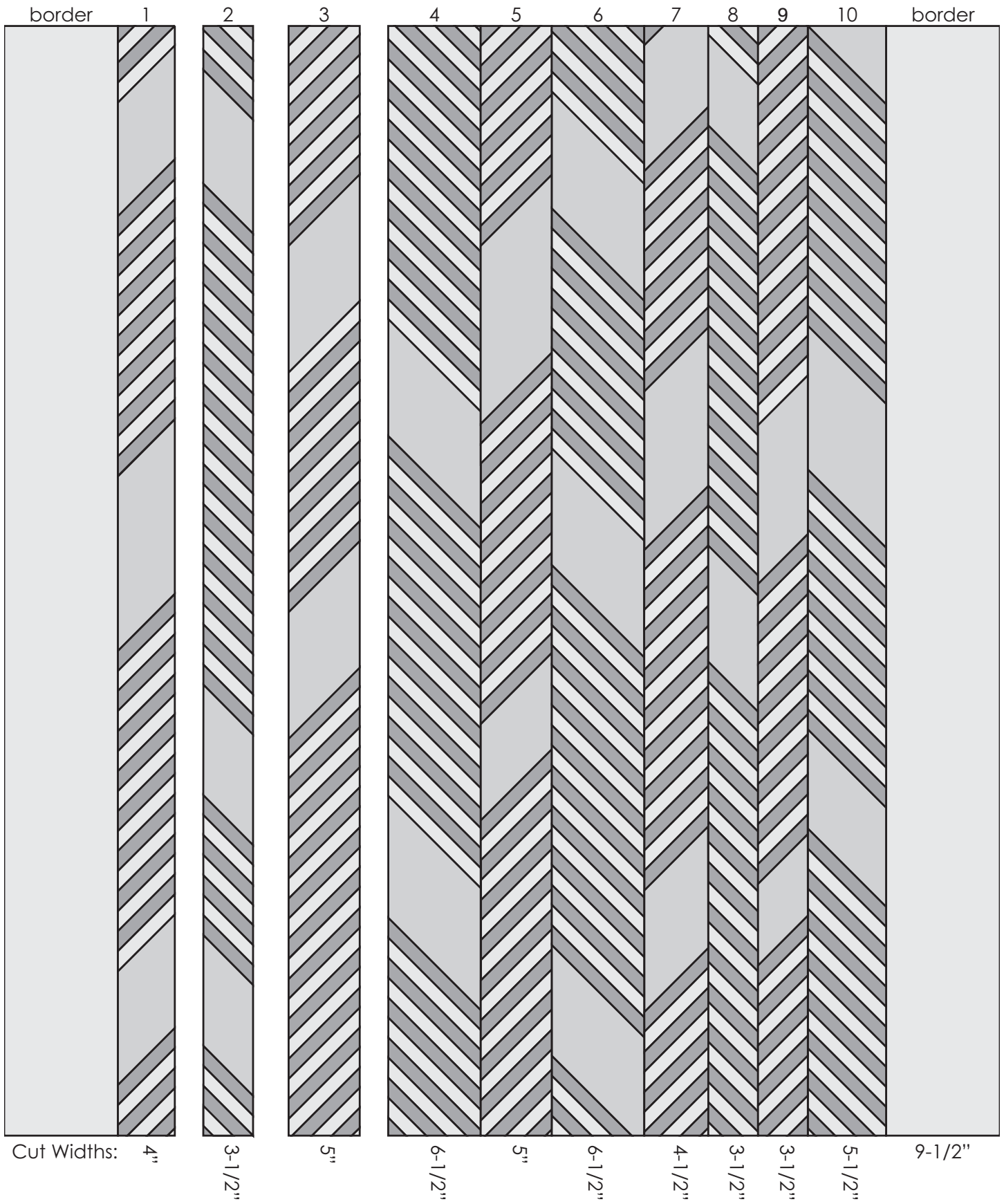

Figure 10

Figure 11



Quilt Assembly Diagram