

# noodlehead



## Cargo Duffel Pattern

structured duffel // cargo pockets // great for traveling

## **Cutting Instructions for Cargo Duffle Bag using Harriot**

*Please refer to the Cargo Duffle Pattern by Noodlehead for all cutting measurements and directions.*

From B198-1015 BEIGE Cut:

- Cotton Canvas Front/Back
- Cotton Canvas Bottom Gusset
- Cotton Canvas Zipper Gusset

AFR-18202-53 BASIL

- From the Scallop Section fussy cut:
  - Quilting Cotton Zipper Gusset
  - Exterior Front Pockets
- From the Green Stripe section cut:
  - Exterior Pocket Flaps
  - Lining Pocket Flaps
  - Accent Handles
- From the Cream Stripe Section cut:
  - Lining Front Pockets

From AFR-18109-39 WILLOW cut

- Interior Binding

From AFR-18110-55 SWEET PEA cut:

- Quilting Cotton Bottom Gusset
- Exterior Bottom Accent
- Handle Main

From AFR-18112-340 LIMESTONE cut:

- Quilting Cotton Front/Back



# Fabric Requirements & Notions:

## + Requirements based on 44" wide fabric.

- 1 yard exterior main
- 3/4 yard bottom accent/bottom gusset
- 3/4 yard pockets/flaps/handle accent
- 1/4 yard handle main
- 1 yard cotton canvas
- 1/2 yard cotton batting (90" wide)
- 1/4 yard interior binding (made into 1/2" double fold straight grain binding)
- 1/2 yard medium weight fusible interfacing for pockets/flap (Pellon SF101)
- 26" Coats & Clark Coverall Zipper (or any closed end zipper 26" long)
- 4 Dritz brand snaps (size 24)

You will need a walking foot and size 16 needle for this project. The number of layers being sewn together makes this essential.

Approx. Finished dimensions:  
18" wide, 11" tall, 6" deep

## Cut Pattern Pieces:

	Quilting cotton	Batting	Cotton Canvas
Front/back	(cut 2) 11.5" tall x 19" wide	(cut 2) 10.5" tall x 18" wide	(cut 2) 11.5" tall x 19" wide
Bottom gusset	6.5" wide x 30.5" long	5.5" wide x 29.5" long	6.5" wide x 30.5" long
Zipper gusset	(cut 2) 3.25" wide x 27.5" long	(cut 2) 2.75" wide x 26.5" long	(cut 2) 3.25" wide x 27.5" long

\*\*\* Depending on the type of quilting you choose to do and variations in fabric, shrinkage after quilting may occur. If you'd like, cut all **quilting cotton pieces** (listed above) 1" larger. Once quilted trim pieces to size listed above. I typically have a small amount of shrinkage after quilting so I cut all my quilting cottons to the sizes listed above.

	Exterior	Lining	Interfacing
Exterior Bottom Accent	(cut 2) 4.5" tall x 19" long	n/a	n/a
Front Pockets	5.5" tall x 19" wide ***	5.5" tall x 19" wide	5.5" tall x 19" wide
Pocket Flaps	(cut 2) 3.75" tall x 6.75" wide	(cut 2) 3.75" tall x 6.75" wide	(cut 2) 3.75" tall x 6.75" wide

\*\*\* Uses 3/4" pleats. Measures approx. 11.5" wide when pleated. Adjust as necessary to align with pocket flaps.

Handles	4.5" wide by 44" long, and one accent piece 3.5" wide by 44" long
Binding	2" wide strips for straight grain double fold binding (finishes at 1/2" wide)



# Sewing Instructions:

RST= Right sides together

WST = Wrong sides together

{1/2" seam allowance used throughout unless otherwise noted}

## Step 1: Make Cargo Pockets

a) Fuse interfacing to front pocket exterior piece. Place front pocket pieces RST. Pin and sew along sides and top edge. Clip corners. Turn right side out. Poke out corners with chopstick or other dull instrument. Press. Edgestitch along sides and top of pocket. Baste along bottom raw edge.



b) Make pleats. Fold pocket in half, mark center along bottom edge. Mark a line 1.5" on each side of center. Mark 1.5" from each finished edge side. To make center pleats, bring marked line to center (exterior fabric RST). For side pleats bring marked line to finished pocket edge (exterior fabric RST). Pin in place. Press well.

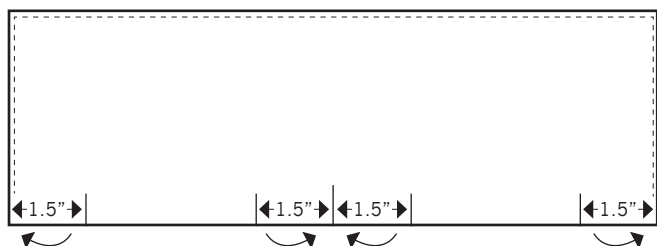

Top view of pleats.



c) Edgestitch along each pleat to hold in place. Press well.





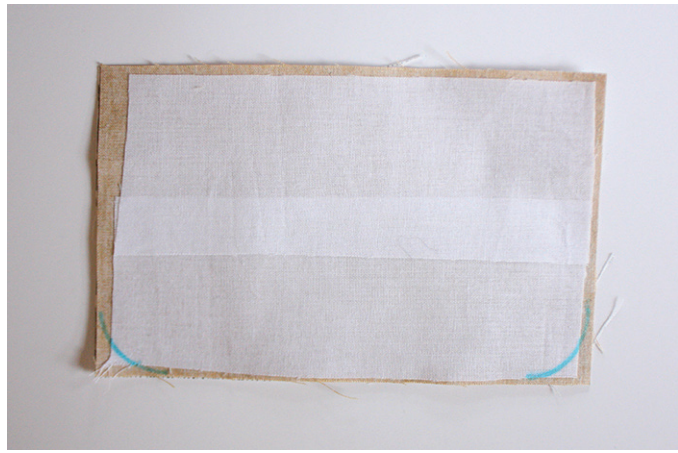

d) Fuse interfacing to pocket flap exterior pieces. Place pocket flap pieces RST. Mark curved edges with small cup. Sew both sides and bottom of pocket flap. Clip curves. Turn right side out. Press. Edgestitch along sides and bottom. Topstitch next to the edgestitching. Repeat for remaining pocket flap.



Set aside.

## Step 2: Assemble Exterior

Use the quilt-as-you-go technique: layer canvas, batting, then quilting cotton on top. I like to place a few pins through all layers to help prevent shifting.



a) Mark a horizontal line 3.5" up from the bottom raw edge of front/back pieces. Quilt until you reach the marked line. Attach pockets to front. Center of pocket will be centered on front exterior, bottom raw edges of pocket will be aligned with the horizontal line you marked previously. Stitch pocket in place, up the center (thus dividing pocket into two) and along each edge, lifting pleats out of the way so as to leave them free and able to expand when used.



b) Press bottom accent piece WST by 1/2". Align raw edge of bottom accent piece with bottom of exterior. Pin in place. Start quilting at top pressed edge of bottom accent piece (this will secure the bottom edge of the pocket) and work down to the bottom edge. Repeat for back exterior piece - skipping pockets.





c) Attach flaps. Press top raw edge of flap (lining sides touching) in by 1/2", repeat for remaining flap. Pin in place on exterior so that the top pressed edge of pocket flap is approximately 3/4" above top edge of cargo pocket. Sew flaps in place by stitching a small rectangle on top edge of each flap.

You will now have a finished front exterior piece and finished back exterior piece.

### Step 3: Make Gusset

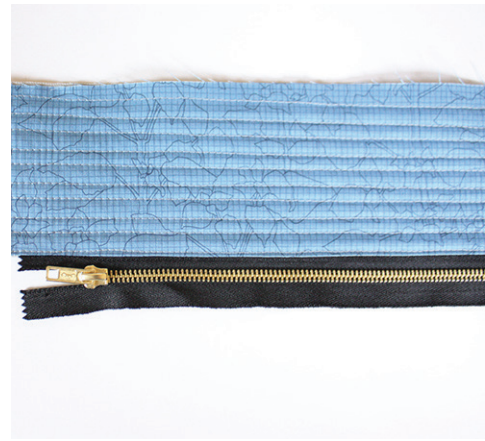

a) Layer canvas, zipper (right side up), then quilting cotton on top of zipper (right side facing down). Sew along edge of zipper using a 1/4" seam allowance. Needle down, lifting presser foot to wiggle zipper pull past needle. Press fabric and canvas away from zipper, WST. Sandwich batting in between and quilt. Repeat for other side of zipper.

b) Quilt bottom gusset piece (again, layering canvas - batting - quilting cotton).

c) Place bottom gusset piece RST with zippered gusset piece. Sew together each short end, thus making a loop and completing the gusset. Apply binding tape to raw edge if desired.



## Step 4: Make Handles



a) Sew accent and main handle piece RST along one long edge. Press long raw edges of both pieces in to meet the stitching line.\* Fold in towards center seam again, this time leaving a small edge of main handle piece showing on each edge. Press. Sew several rows of topstitching along length of handle. Cut handle piece in half.



\* At this point you could insert a 1.25" wide strip of leftover canvas to add extra durability to the strap.

## Step 5: Assemble Duffle

a) Baste handles in place. Mark center of front/back pieces. Center handles 5" apart (with accent fabric RST with exterior). Baste in place on front exterior and back exterior, being sure not to twist handle.

b) Mark with a dot 1/2" from all corners of both exterior front/back pieces on canvas side. These dots will help guide where to start and stop in step c).

c) Mark center of front/back pieces at top and bottom edges. Mark center of bottom gusset and zipper gusset at top and bottom edges.

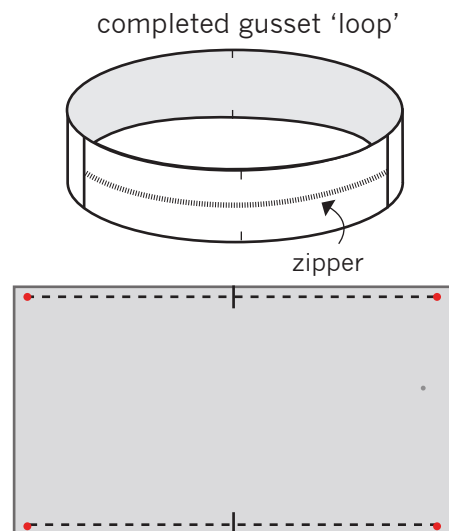

d) Match center of zipper gusset to the TOP marked center of front, RST. Pin or use Clover binding clips to hold in place. Sew from dot to dot, beginning with the top seam and bottom seam of bag, then sewing each side seam. This will help ensure that everything will line up correctly.

e) Open zipper.

f) Repeat step d) to attach gusset to the back exterior piece.

## Step 6: Finish Duffle

a) Make and attach binding strips to raw edges. Be sure to go very slow. There are lots of layers. Be sure to use a size 16 needle. Miter corners. Turn right side out!

b) Attach snaps on pocket & flaps as desired. You're finished!