

CANYON CRITTERS

Designed by Wishwell for RK
www.robertkaufman.com

Featuring **HIDDEN CANYON**

Wishwell
fabric for daydreamers.



Finished quilt measures: 78-1/2" x 94-1/2"

Difficulty Rating: **Advanced**

ROBERTKAUFMAN
F A B R I C S

For questions about this pattern, please email Patterns@RobertKaufman.com.

Fabric and Supplies Needed

Fabric amounts based on yardage that is 42" wide.

Color	Fabric	Name/SKU	Yardage	Color	Fabric	Name/SKU	Yardage
	A	WEL-19808-86 EGGSHELL	3 yards		J	WEL-19806-82 BLUE JAY	1/3 yard
	B	WEL-19807-43 LEAF	1/2 yard		K	WEL-19808-63 SKY	1/3 yard
	C	WEL-19809-30 FERN	1/2 yard		L	WEL-19807-438 NIGHT	1/2 yard
	D	WEL-19806-438 NIGHT	3/4 yard		M	WEL-19809-98 STRAWBERRY	1/3 yard
	E	WEL-19809-259 BLACKBERRY	1 yard		N	WEL-19806-99 CHERRY	1/3 yard
	F	WEL-19805-82 BLUE JAY	1-1/8 yards		O	WEL-19809-166 HAZELNUT	1/3 yard
	G	WEL-19809-270 MEADOW	1/3 yard		P	WEL-19806-378 CEDAR	1/4 yard
	H	WEL-19807-73 LAKE	3/8 yard		Binding*	WEL-19806-438 NIGHT	2/3 yard
	I	WEL-19808-125 SUNFLOWER	1/4 yard	*Also used for Fabric D			

Copyright 2020, Robert Kaufman
For individual use only - Not for resale

You will also need:
7-1/4 yards for backing
8 yards Fusible web

Notes Before You Begin

- Read through all of the instructions before beginning.
- All of the seam allowances are 1/4" unless otherwise noted.
- Press seam allowances open unless otherwise noted.
- Width of fabric (WOF) is equal to at least 42" wide.
- Right sides together has been abbreviated to RST.
- Remember to measure twice and cut once!

Cutting Instructions

From Fabric A, cut:

four 14" x WOF strips. Subcut:

ten 14" squares

fourteen 2" x 14" rectangles for the Bear Paw Block borders

five 2-1/2" x WOF strips. Subcut:

eighty 2-1/2" squares for the HSTs

seventeen 2" x WOF strips. Subcut:

six 2" x 14" rectangles for the Bear Paw Block borders

twenty 2" x 11" rectangles for the Bear Paw Block borders

forty 2" x 5" rectangles for the Bear Paw Blocks

forty 2" squares for the Bear Paw Blocks

six sets of Templates 14-21

one each of Templates 74, 81, 101, 114, 115 and 116

From Fabric B, cut:

two 3-1/2" x WOF strips. Sew together, end-to-end, then trim:

one 3-1/2" x 68" strip

three of Template 11

three of Template 12

From Fabric C, cut:

two 4-1/2" x WOF strips. Sew together, end-to-end, then trim:

one 4-1/2" x 68" strip

three of Template 23

three of Template 25

three of Template 27

four of Template 29-37

From Fabric D, cut:

one 14" x WOF strip. Subcut:

three 14" squares

one 2-1/2" x WOF strip. Subcut:

sixteen 2-1/2" squares for the HSTs

four 2" x WOF strips. Subcut:

four 2" x 14" rectangles for the Bear Paw Block borders

four 2" x 11" rectangles for the Bear Paw Block borders

eight 2" x 5" rectangles for the Bear Paw Blocks

eight 2" squares for the Bear Paw Blocks

From Fabric E, cut:

eight 2" x WOF strips. Sew together, end-to-end, then trim:
two 2" x 84" side inner borders
two 2" x 71" top/bottom inner borders
one of Template 73, 78, 79, 92, 93, and 110-113
four of Template 2

From Fabric F, cut:

eight 4-1/2" x WOF strips. Sew together, end-to-end, then trim:
two 4-1/2" x 87" side outer borders
two 4-1/2" x 71" top/bottom outer borders

From Fabric G, cut:

one 3-1/2" x WOF strip. Subcut:
twelve 3-1/2" squares
two 2-1/2" x WOF strip. Subcut:
twenty-four 2-1/2" squares for the HSTs
Trim the remainder of the second strip to 2" wide, then subcut:
two 2" squares

From Fabric H, cut:

four of Template 1
three of Template 24
three of Template 26
three of Template 28
one of Template 117

From Fabric I, cut:

two 2" squares
three of Template 12
seven each of Templates 3-10
one of Template 49, 50, 56, 57, 64, 65, 72, 76, 77

From Fabric J, cut:

one 4-1/2" x WOF strip. Subcut:
four 4-1/2" squares
one 3-1/2" x WOF strip. Subcut:
eight 3-1/2" squares
Trim the remainder of the strip to 2" wide, then subcut:
two 2" squares
one 2-1/2" x WOF strip. Subcut:
sixteen 2-1/2" squares for the HSTs

From Fabric K, cut:

Three of Template 1 and 22

From Fabric L, cut:

two 2" squares
one 3-1/2" x WOF strip. Subcut:
 eight 3-1/2" squares
one 2-1/2" x WOF strip. Subcut:
 sixteen 2-1/2" squares for the HSTs
three of Template 2
four of Templates 44-46
six of Template 13
one of Template 70
one of Template 99

From Fabric M, cut:

one 3-1/2" x WOF strip. Subcut:
 twelve 3-1/2" squares
two 2-1/2" x WOF strip. Subcut:
 twenty-four 2-1/2" squares for the HSTs
Trim the remainder of the second strip to 2" wide, then subcut:
 two 2" squares
four of Templates 11, 41-43
three of Template 22
one of Template 98 and 118

From Fabric N, cut:

one 3-1/2" x WOF strip. Subcut:
 eight 3-1/2" squares
Trim the remainder of the second strip to 2" wide, then subcut:
 two 2" squares
one 2-1/2" x WOF strip. Subcut:
 sixteen 2-1/2" squares for the HSTs
four of Templates 38-40
one of Template 97

From Fabric O, cut:

one of Templates 47, 54, 61, 69, 80, 100

From Fabric P, cut:

one of Templates 48, 51-53, 55, 58-60, 62, 63, 66-68, 71, 75, 82-91, 99-102

From the Binding Fabric, cut:

nine 2-1/2" x WOF strips

Prepare the Templates

Step 1: Copy all templates at 100%.

Step 2: On the fusible web, trace the indicated number of each Template, as instructed on the Template sheets. Be sure to note the quantity. Tip: In addition to the piece number, include the fabric letter shown on the Template. This will help you to ensure you are fusing it to the correct fabric.

Step 3: Cut out each traced shape, leaving 1/4"-1/2" of excess fusible web outside the marked lines. You will NOT cut on the marked/traced lines at this point.

Step 4: Follow in the steps below to fuse each piece to the appropriate fabric. Fuse, following the manufacturer's instructions, then cut out each shape on the marked line.

Assemble the Bear Paw Blocks

Step 1: Pair a 2-1/2" Fabric A square with a 2-1/2" Fabric G square, RST. Mark a diagonal line on the wrong side of one square. Sew 1/4" away from both sides of the marked line. Cut on the marked line, creating two half-square triangles (HSTs). Press toward the darker fabric. Trim to 2" square. Repeat to make thirty-two A/G HSTs.



Step 2: Repeat Step 1 to make:



thirty-two A/M HSTs



thirty-two A/L HSTs



thirty-two A/N HSTs



thirty-two A/J HSTs



sixteen D/G HSTs



sixteen D/M HSTs

Step 3: Gather:

four A/G HSTs

one 2" Fabric A square

one 3-1/2" Fabric G square

Arrange as shown, noting the orientation of the HSTs. Sew the HSTs together as shown to form pairs. Press.

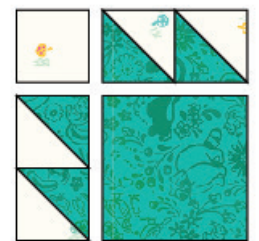

Sew the units together to form two rows. Press away from the HST pairs. Sew the rows together to form the larger unit. Press. The larger unit should measure 5" square.

Repeat to make four larger units.

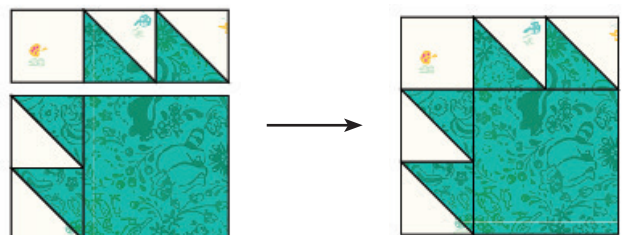

Step 4: Gather:
 four large units from Step 3
 four 2" x 5" Fabric A rectangles
 one 2" Fabric N square

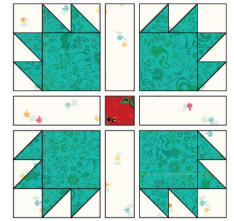

Arrange as shown in the Block Assembly Diagram. Sew the units together in three rows of three. Press the seams away from the Fabric A rectangles. Sew the rows together to form the block center. Press.

Step 5: Sew a 2" x 11" Fabric A strip to the top and bottom edges of the block. Press. Sew a 2" x 14" Fabric A strip to the left and right edges of the block. Press.
 The Bear Paw Block should measure 14" square. Repeat to make:

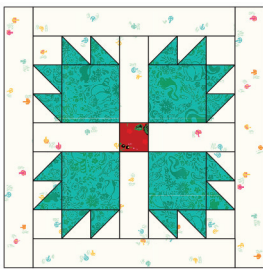

two Bear Paw Blocks
 from Fabrics A/G

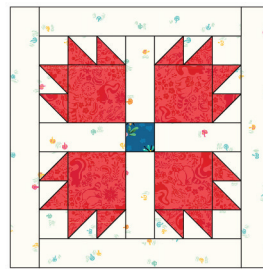

two Bear Paw Blocks
 from Fabrics A/M

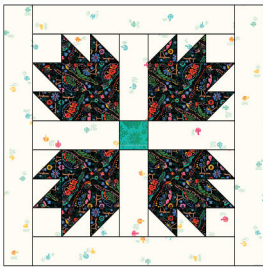

two Bear Paw Blocks
 from Fabrics A/L

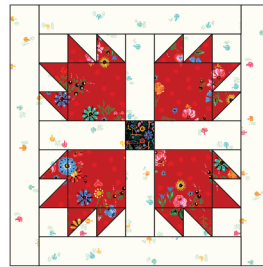

two Bear Paw Blocks
 from Fabrics A/N

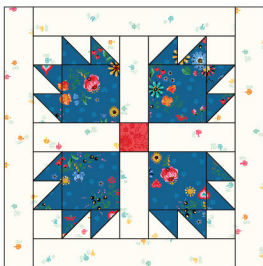

two Bear Paw Blocks
 from Fabrics A/J

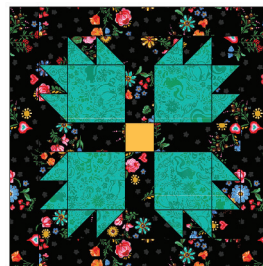

one Bear Paw Block
 from Fabrics D/G



one Bear Paw Block
 from Fabrics D/M

Assemble the Flower Blocks

Step 6: Using the Appliqué Placement diagram as a guide, place the assorted Template pieces in the pairings indicated. Pin in place. One piece at a time, peel the paper backing from the lower layer Template pieces and fuse to the 14" Fabric A squares. Continue by peeling the backing to the upper layer Template pieces and fusing to the Blocks as indicated in the Quilt Assembly Diagram. Edge stitch the templates to the block.

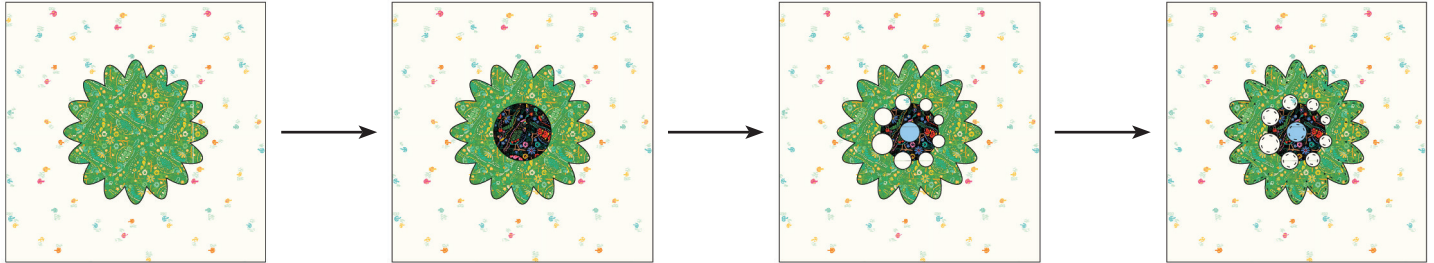

Repeat to make nine Flower Blocks in a Fabric A base and three Flower Blocks on a Fabric D base.

Assemble the Squirrel Panel

Step 7: Sew the 68" long Fabric A, B and C strips together. Press. Using the same process as described in Step 6, arrange, pin, press and stitch each Template piece in place.



Assemble the Quilt



Step 8: Arrange the blocks into four rows of five blocks to form the upper section of the Quilt Center. Note the fabric placement and block orientation in the Quilt Assembly Diagram.

Step 9: Arrange the blocks into one row of five blocks to form the lower section of the Quilt Center. Note the fabric placement and block orientation in the Quilt Assembly Diagram.

Step 10: Sew the lower section to the Squirrel Panel, then sew the upper section to the unit to form the quilt center. Press.

Step 11: Sew the side inner borders to the sides of the quilt center. Press toward the borders. Sew the top and bottom inner borders to the quilt center. Press toward the borders.

Step 12: Sew the side outer borders to the sides of the quilt center. Press toward the borders. Sew the top and bottom outer borders to the quilt center. Press toward the borders.

Your quilt top is complete! Baste, quilt, bind and enjoy!

Templates

SMALL ROUND FLOWER

PIECE 12 (flower background):

WEL-19807-43 LEAF x 3

WEL-19808-125 SUNFLOWER x 3

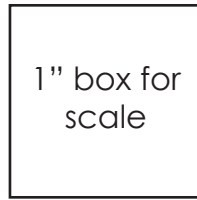

ROBERTKAUFMAN
F A B R I C S
CANYON CRITTERS
TEMPLATES

PIECE 13:

WEL-19807-438 NIGHT x 6

PIECES 14-21:

WEL-19808-86 EGGSHELL x 6

PIECE 22:

WEL-19808-63 SKY x 3

WEL-19809-98 STRAWBERRY x 3

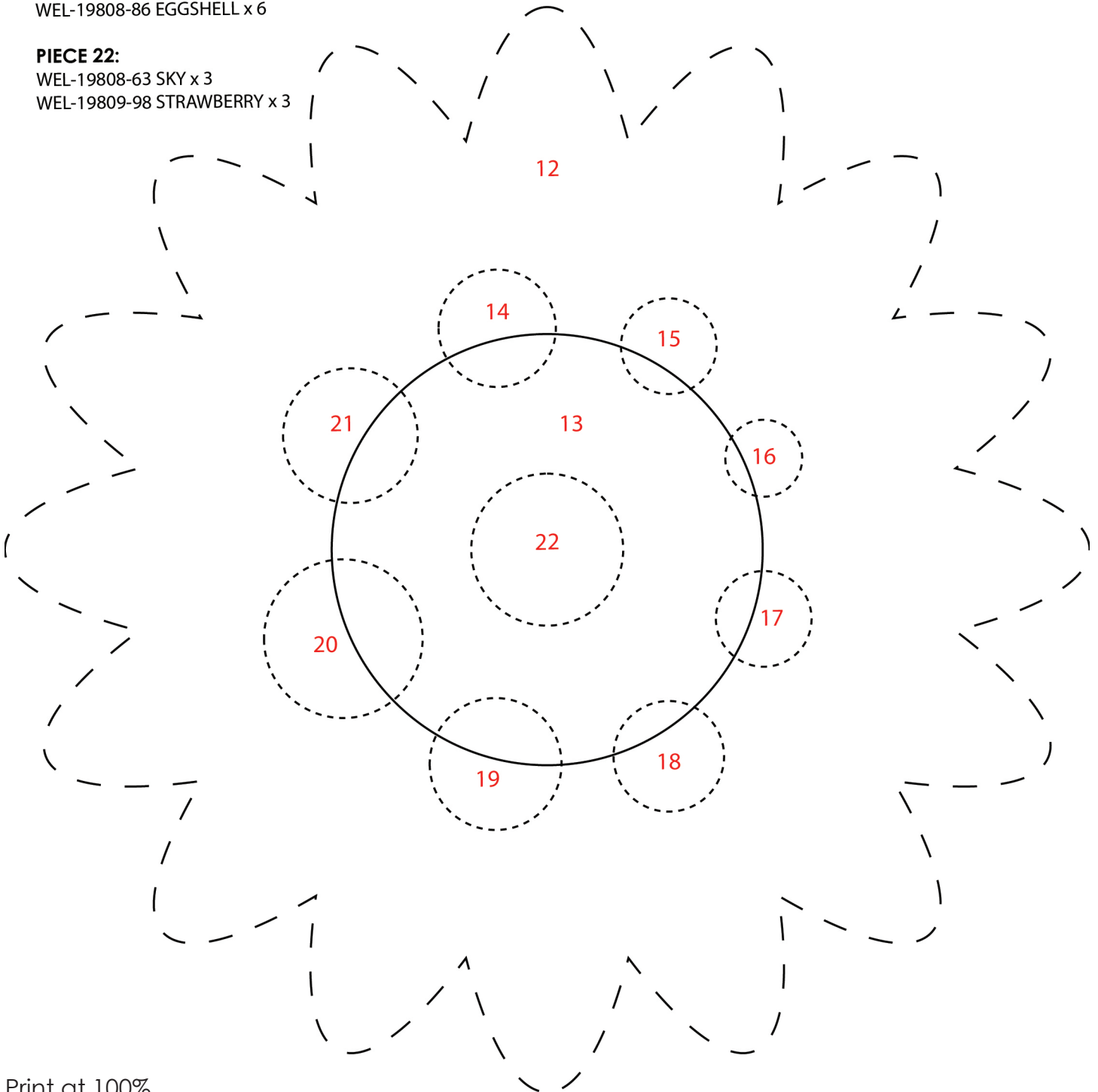

Print at 100%.

Check size printed correctly using 1" box for scale prior to cutting fabric.

Templates shown in reverse.

LARGE ROUND FLOWER

PIECE 1 (flower background):

WEL-19807-73 LAKE x 4

WEL-19808-63 SKY x 3

PIECE 2:

WEL-19809-259 BLACKBERRY x 4

WEL-19807-438 NIGHT x 3

1" box for
scale

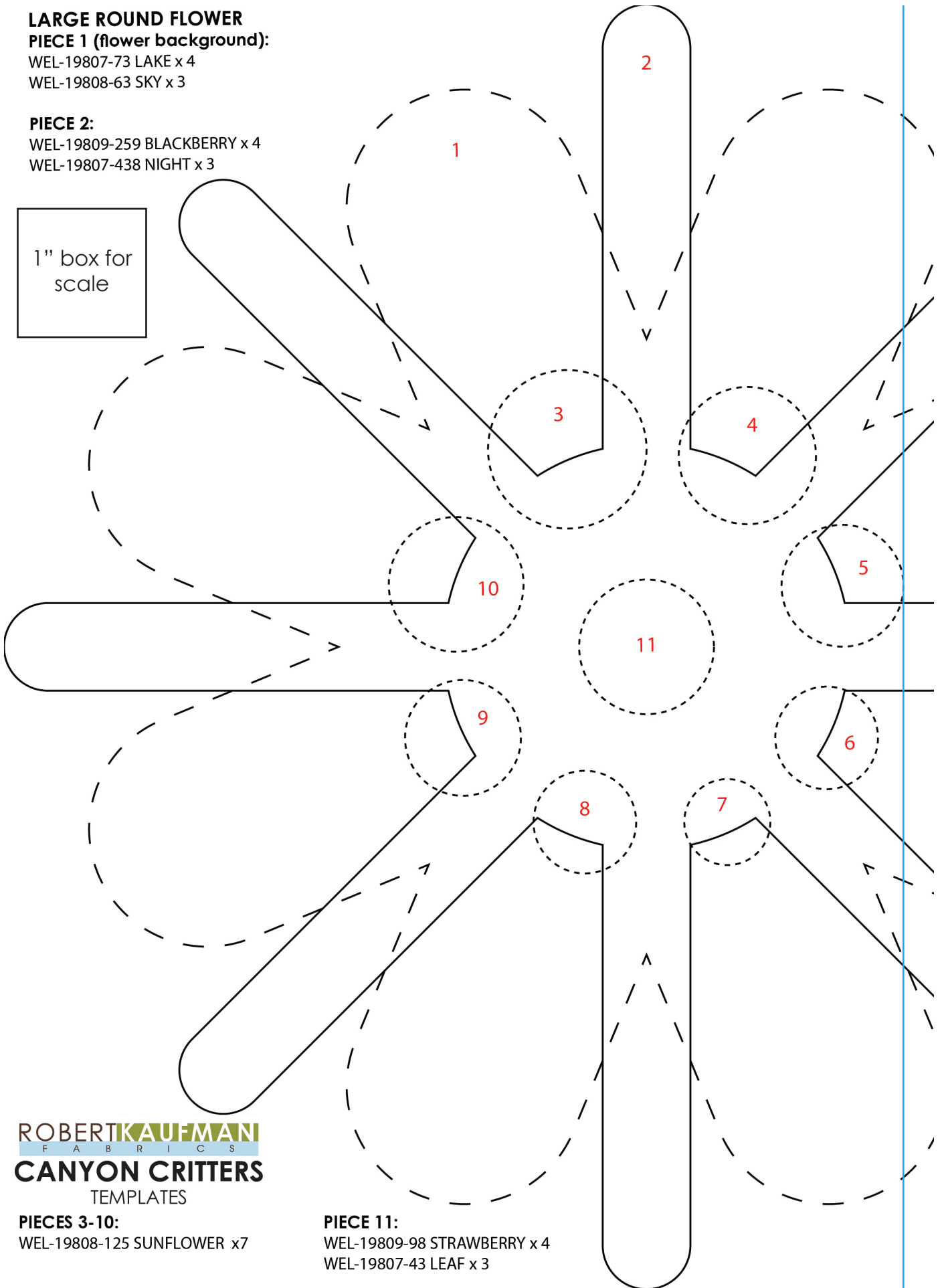

ROBERTKAUFMAN
F A B R I C S
CANYON CRITTERS
TEMPLATES

PIECES 3-10:

WEL-19808-125 SUNFLOWER x7

PIECE 11:

WEL-19809-98 STRAWBERRY x 4

WEL-19807-43 LEAF x 3

CANYON CRITTERS
TEMPLATES

1" box for
scale

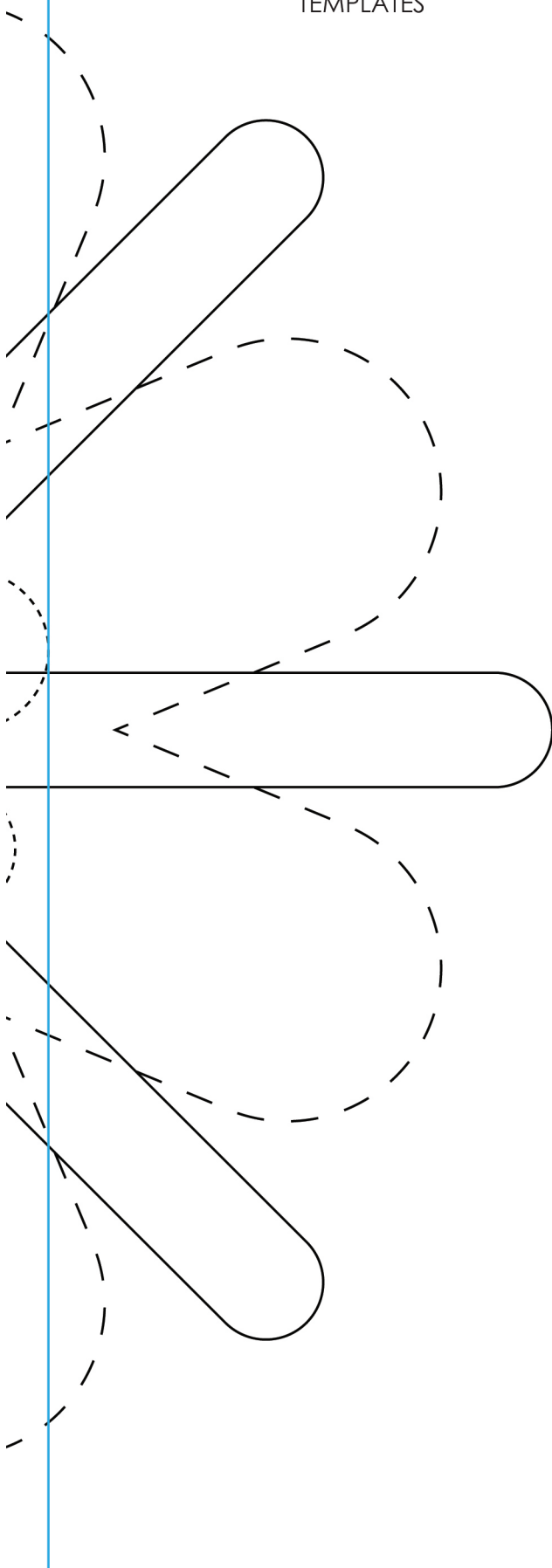

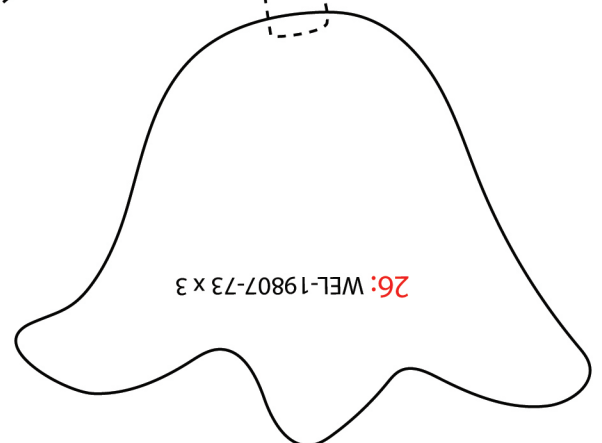
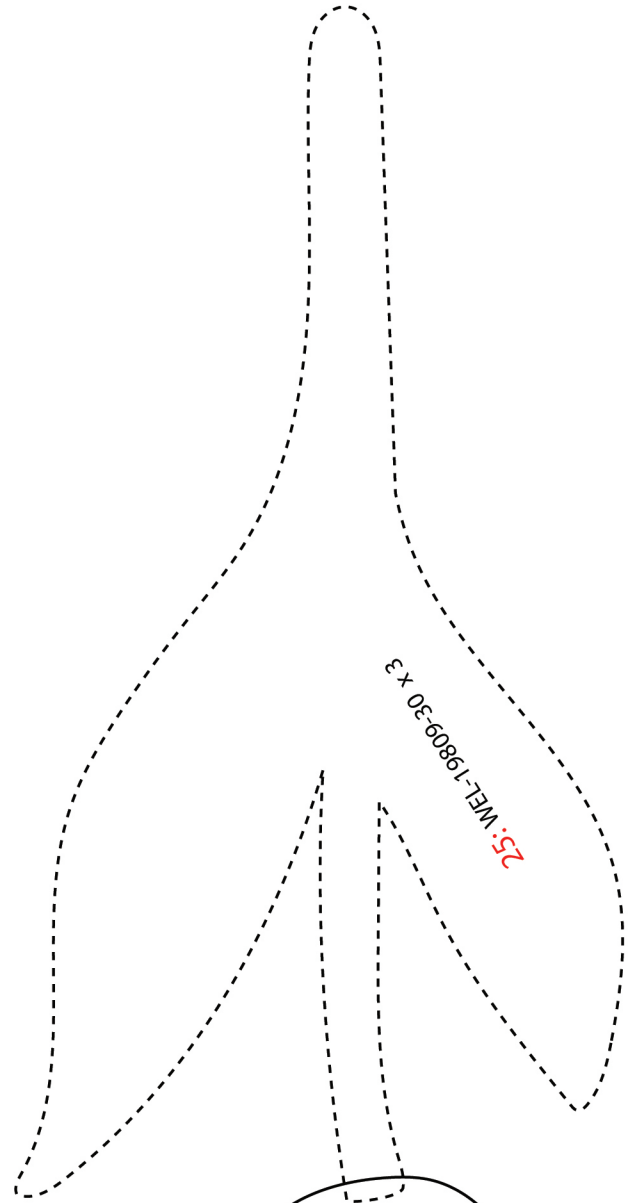
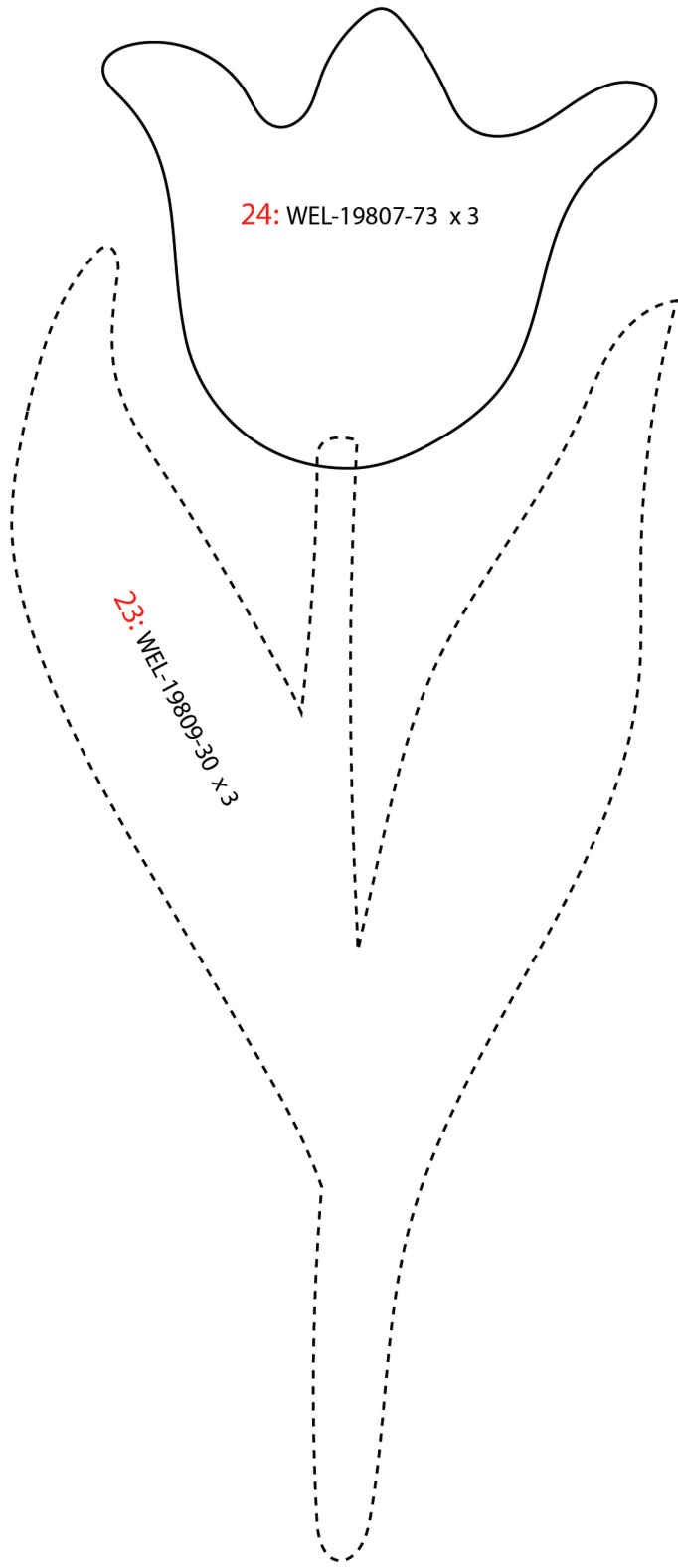

1" box for
scale

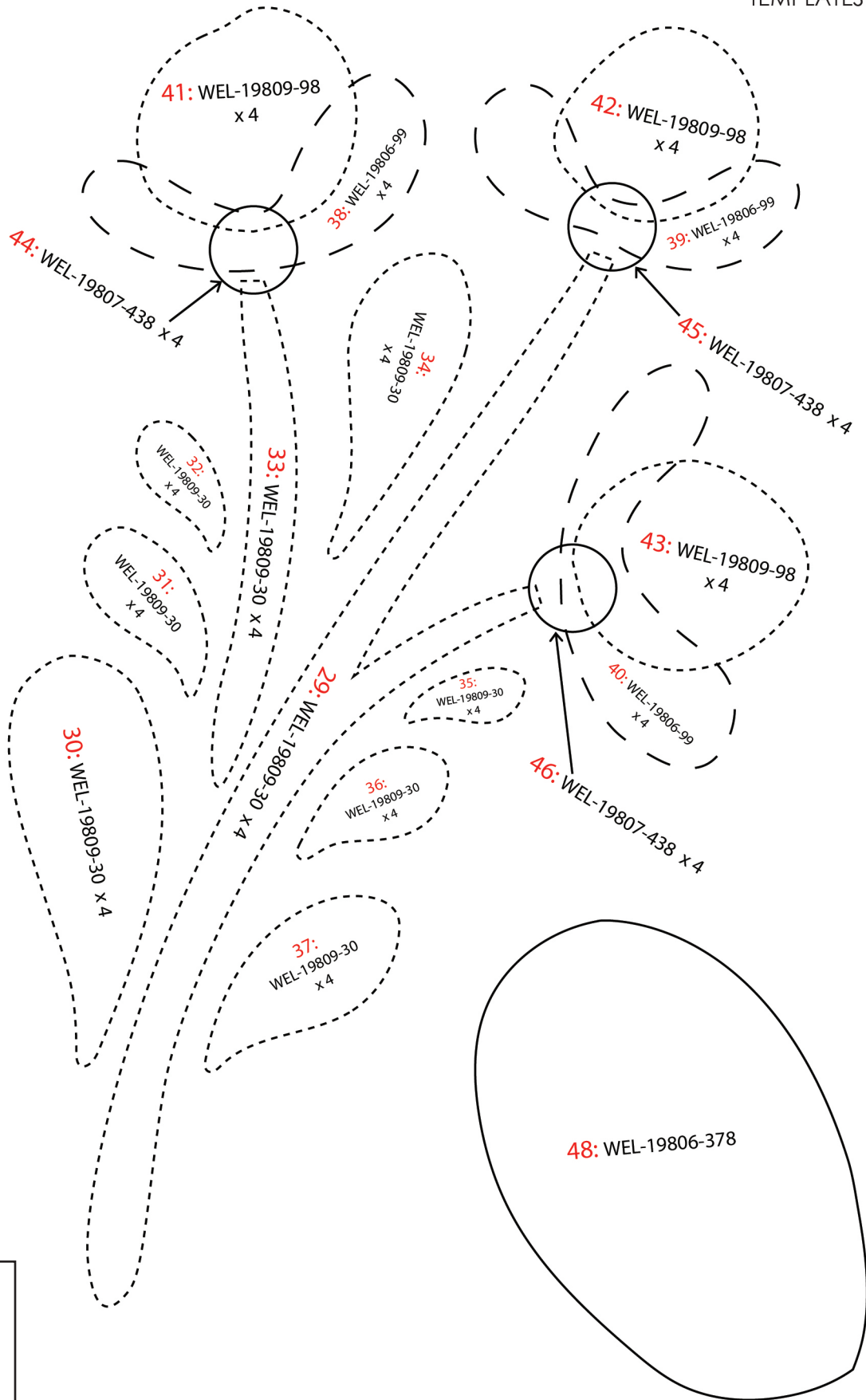

1" box for
scale

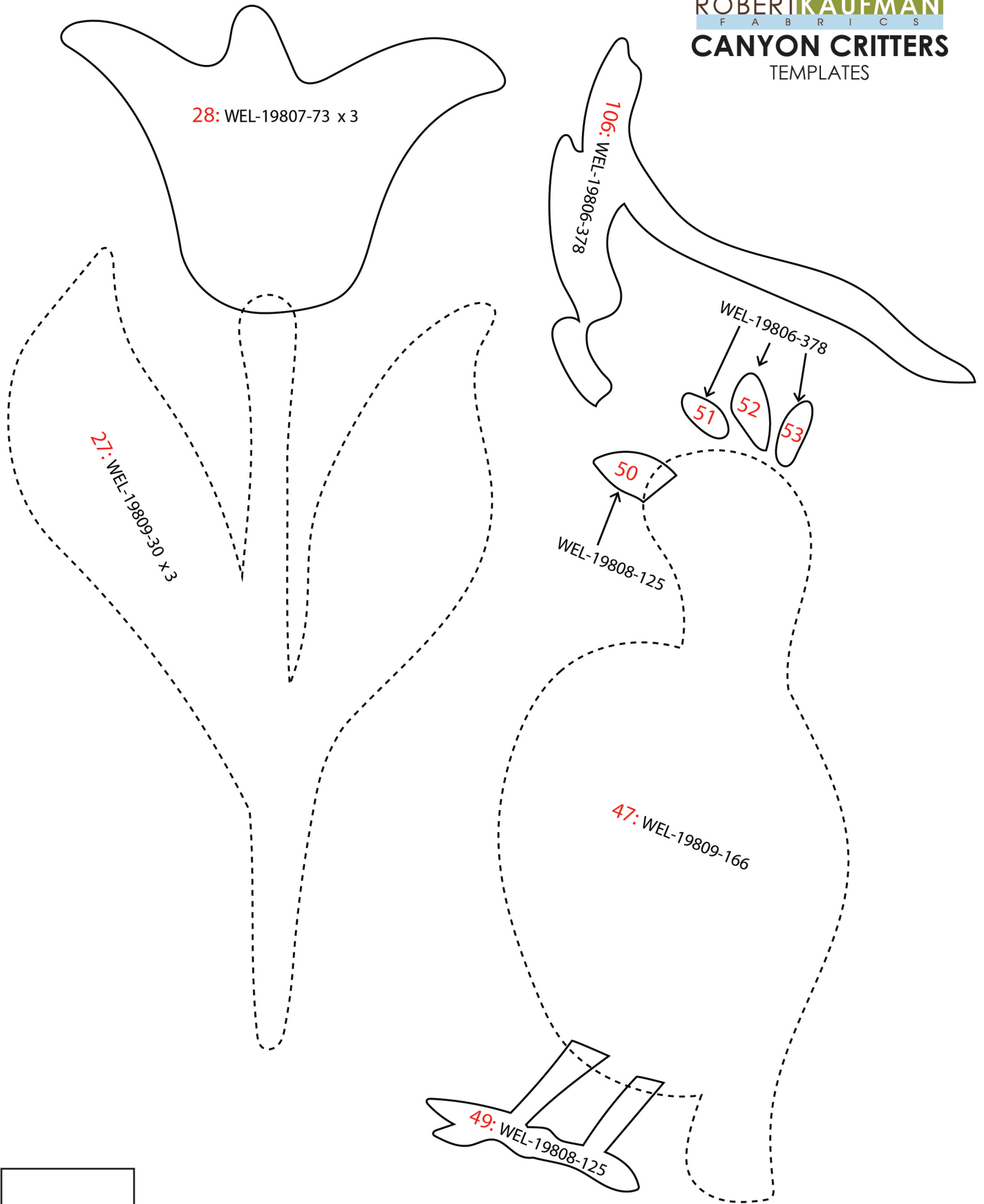

1" box for
scale

ROBERT KAUFMAN
F A B R I C S
CANYON CRITTERS
TEMPLATES

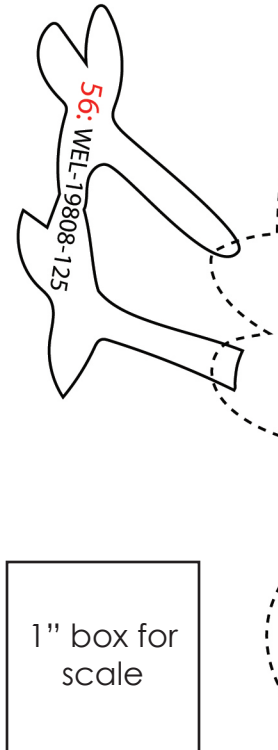
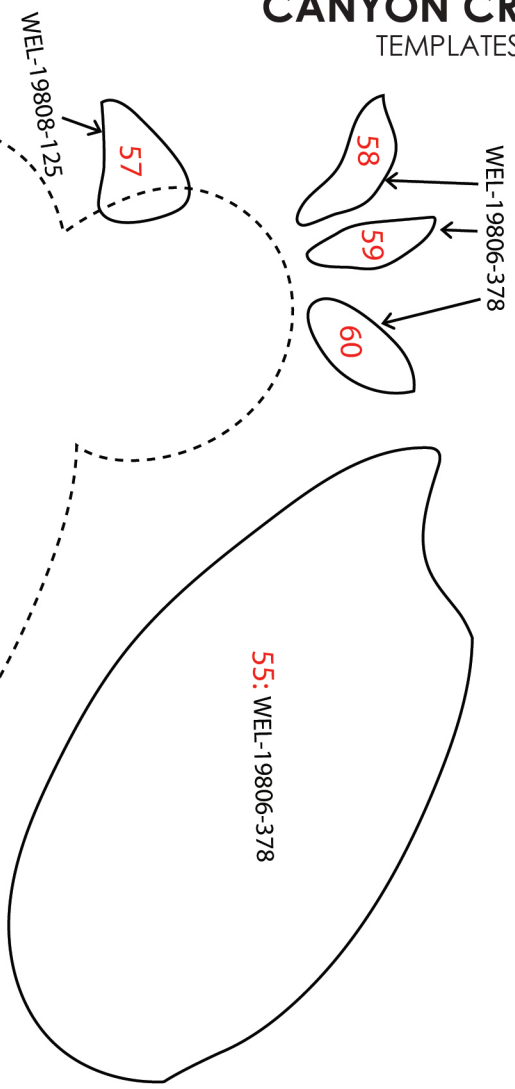
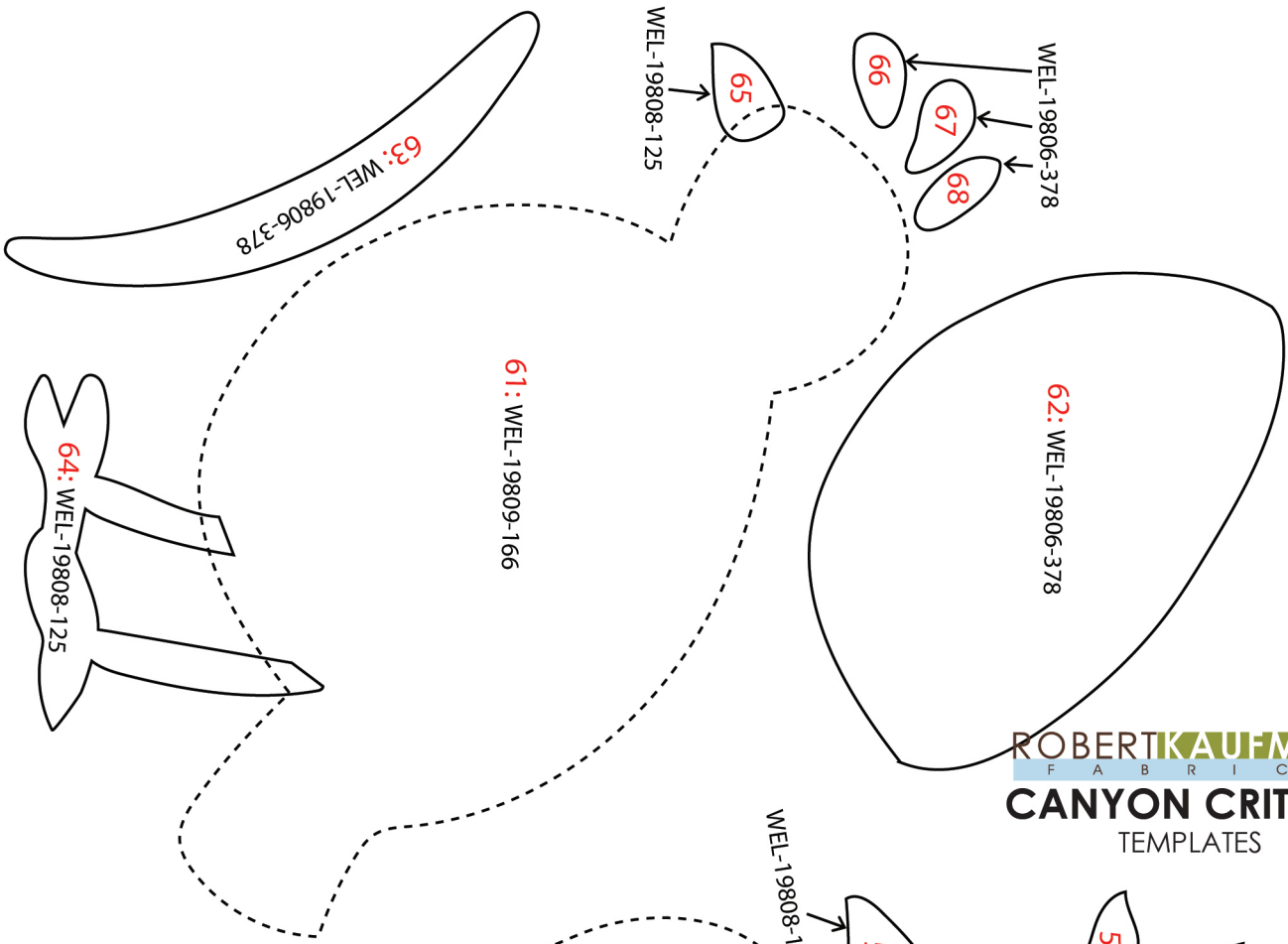

1" box for scale

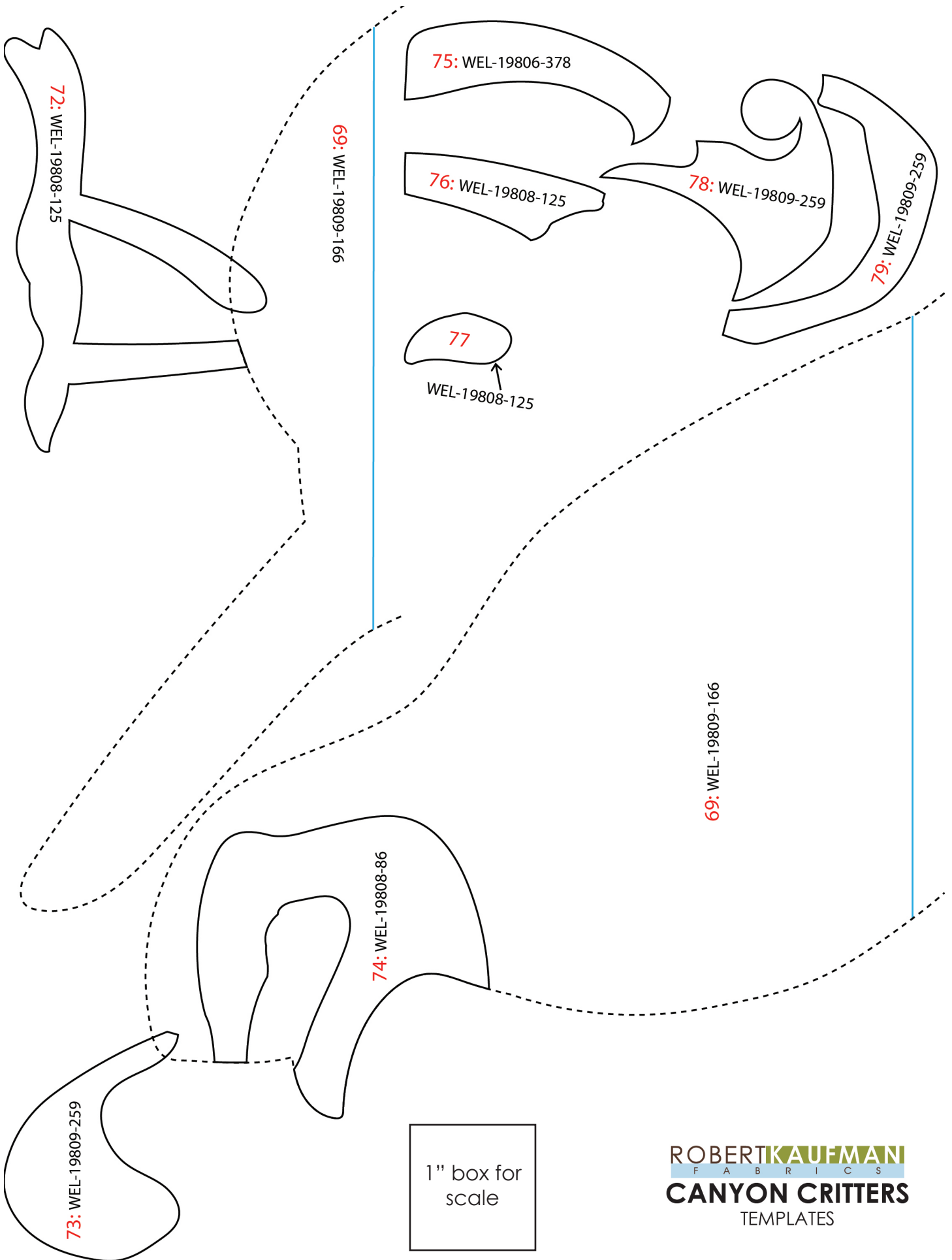

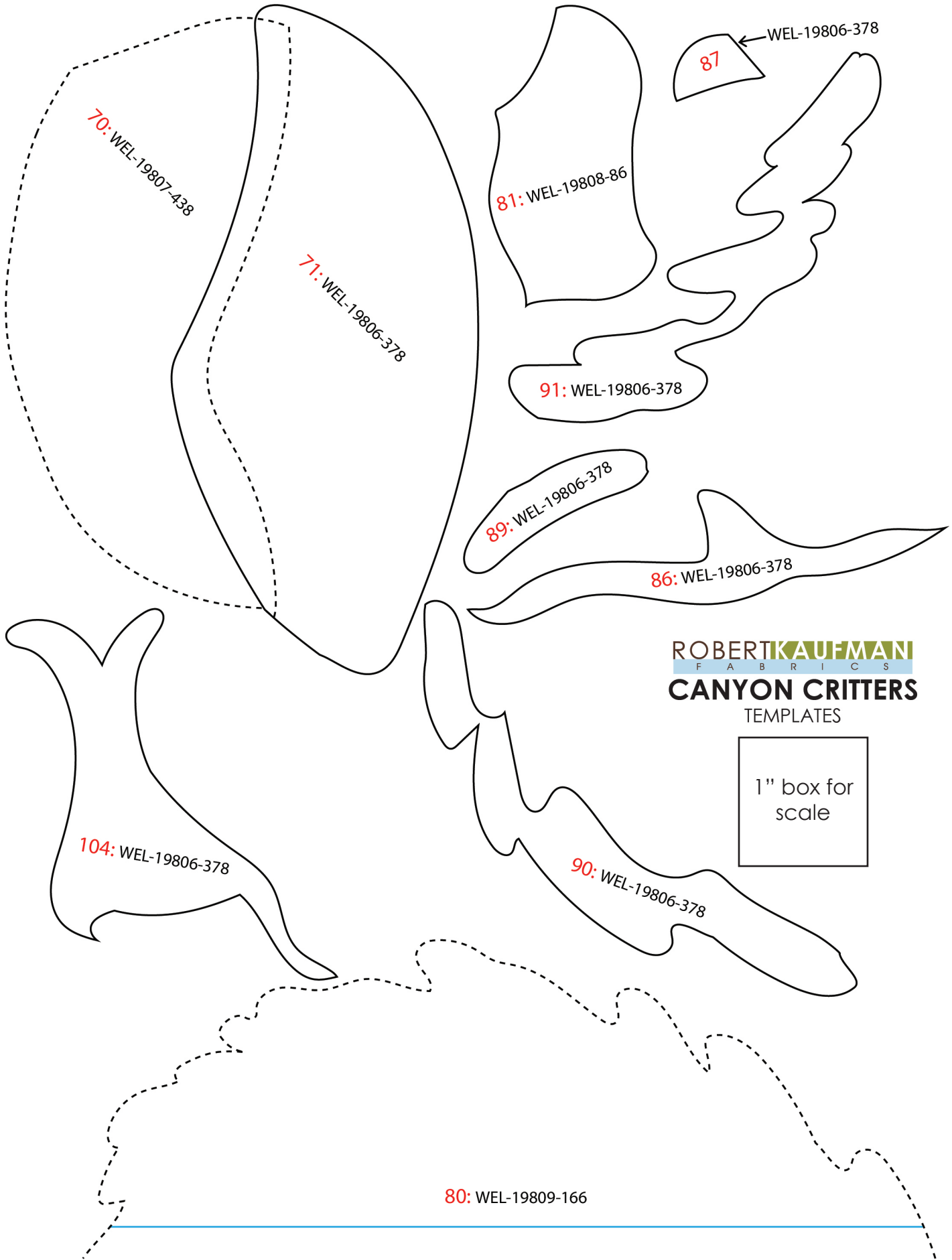

70: WEL-19807-438

71: WEL-19806-378

81: WEL-19808-86

87

WEL-19806-378

91: WEL-19806-378

89: WEL-19806-378

86: WEL-19806-378

104: WEL-19806-378

90: WEL-19806-378

80: WEL-19809-166

ROBERT KAUFMAN
F A B R I C S

CANYON CRITTERS

TEMPLATES

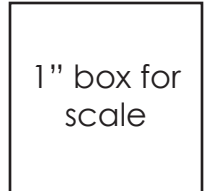

1" box for
scale

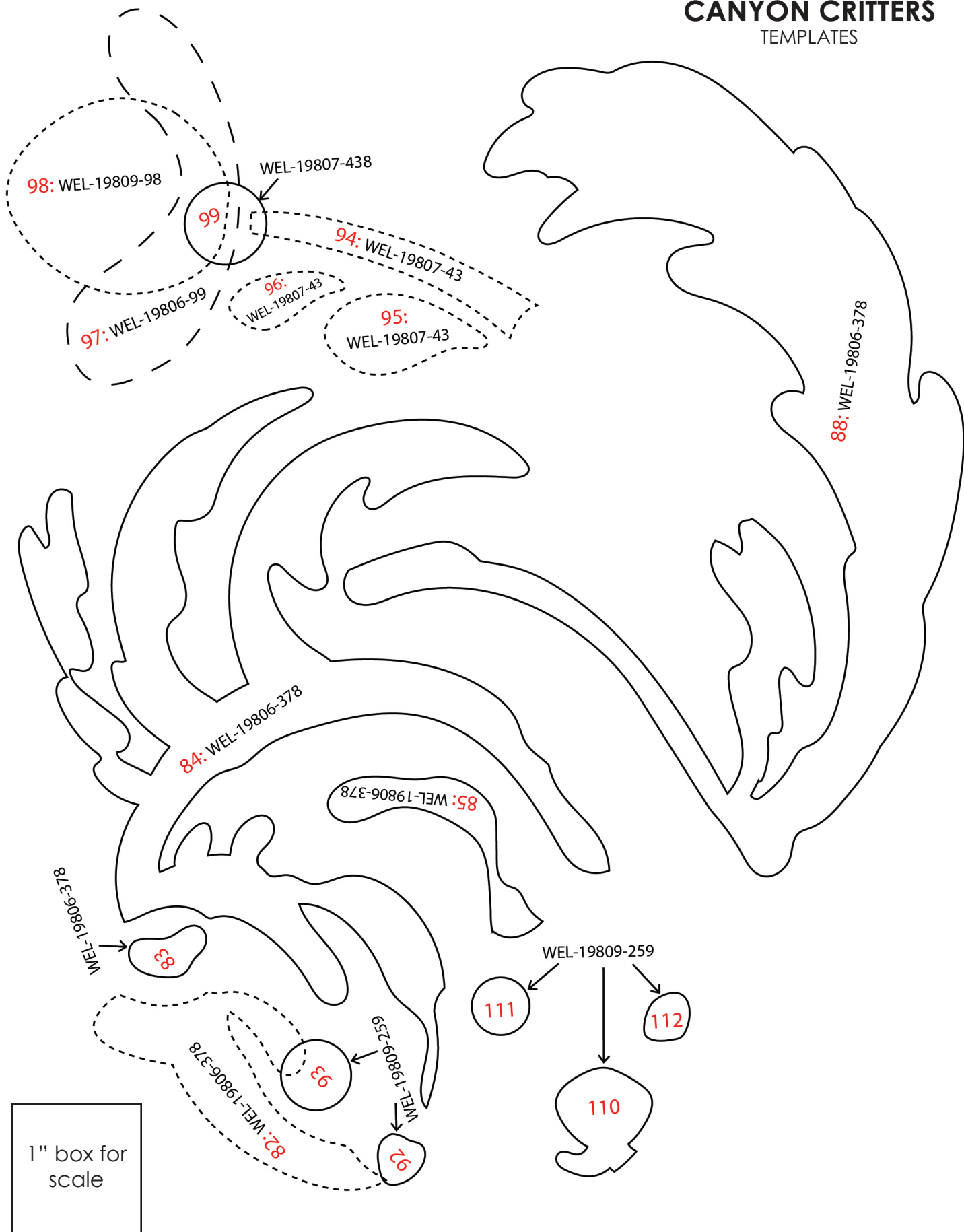

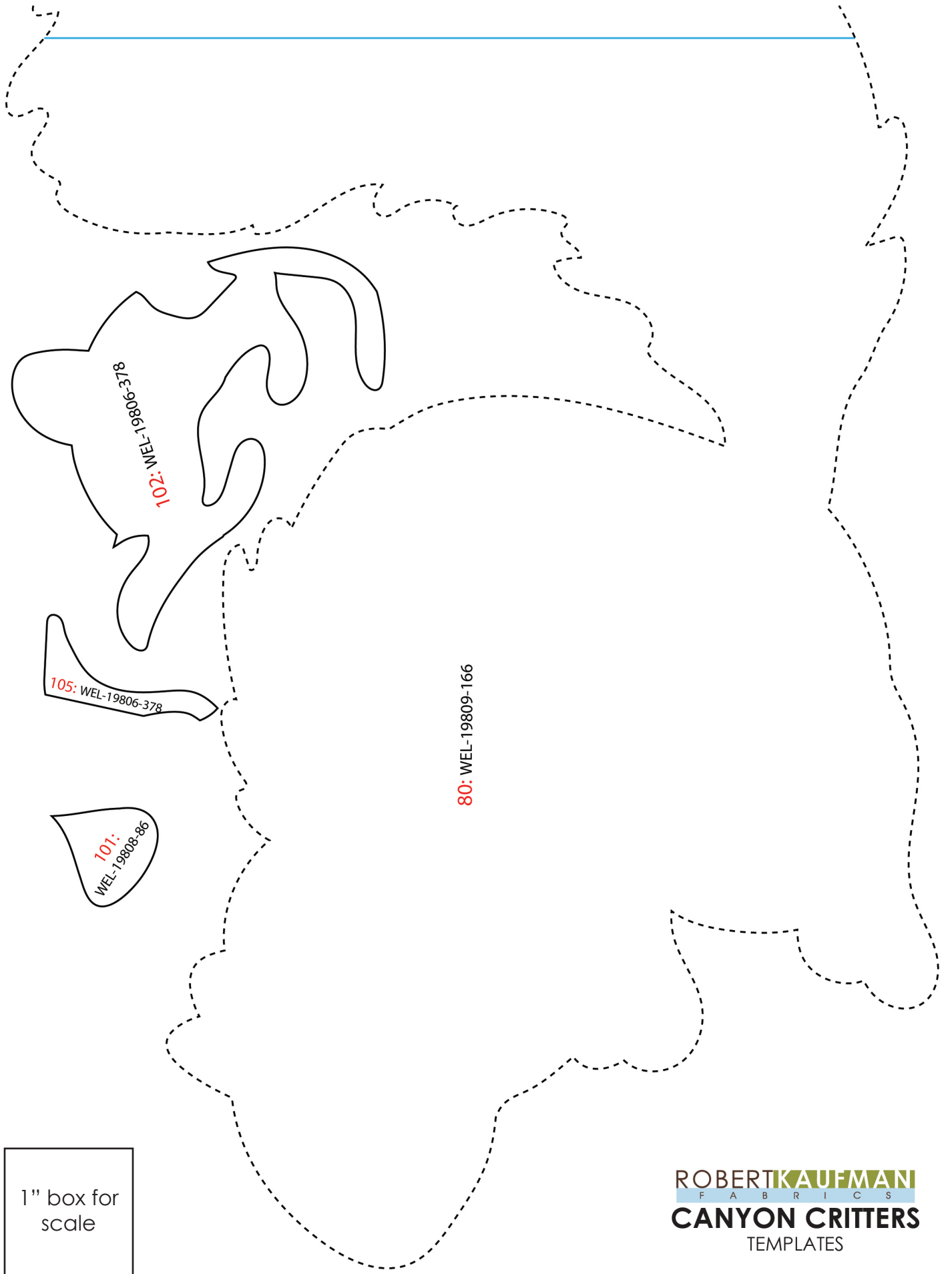

1" box for
scale

ROBERTKAUFMAN
F A B R I C S
CANYON CRITTERS
TEMPLATES

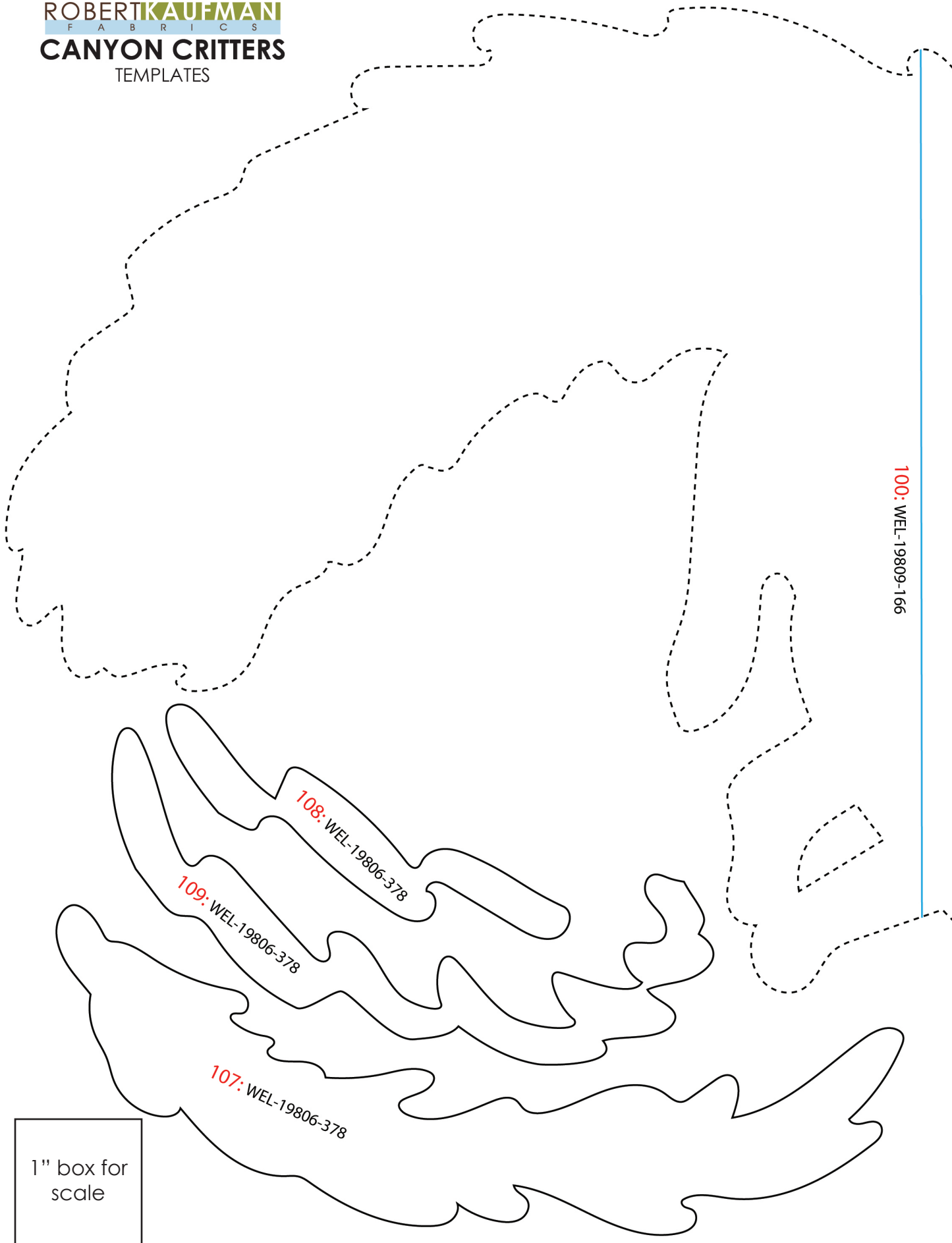

100: WEL-19809-166

108: WEL-19806-378

109: WEL-19806-378

107: WEL-19806-378

1" box for
scale

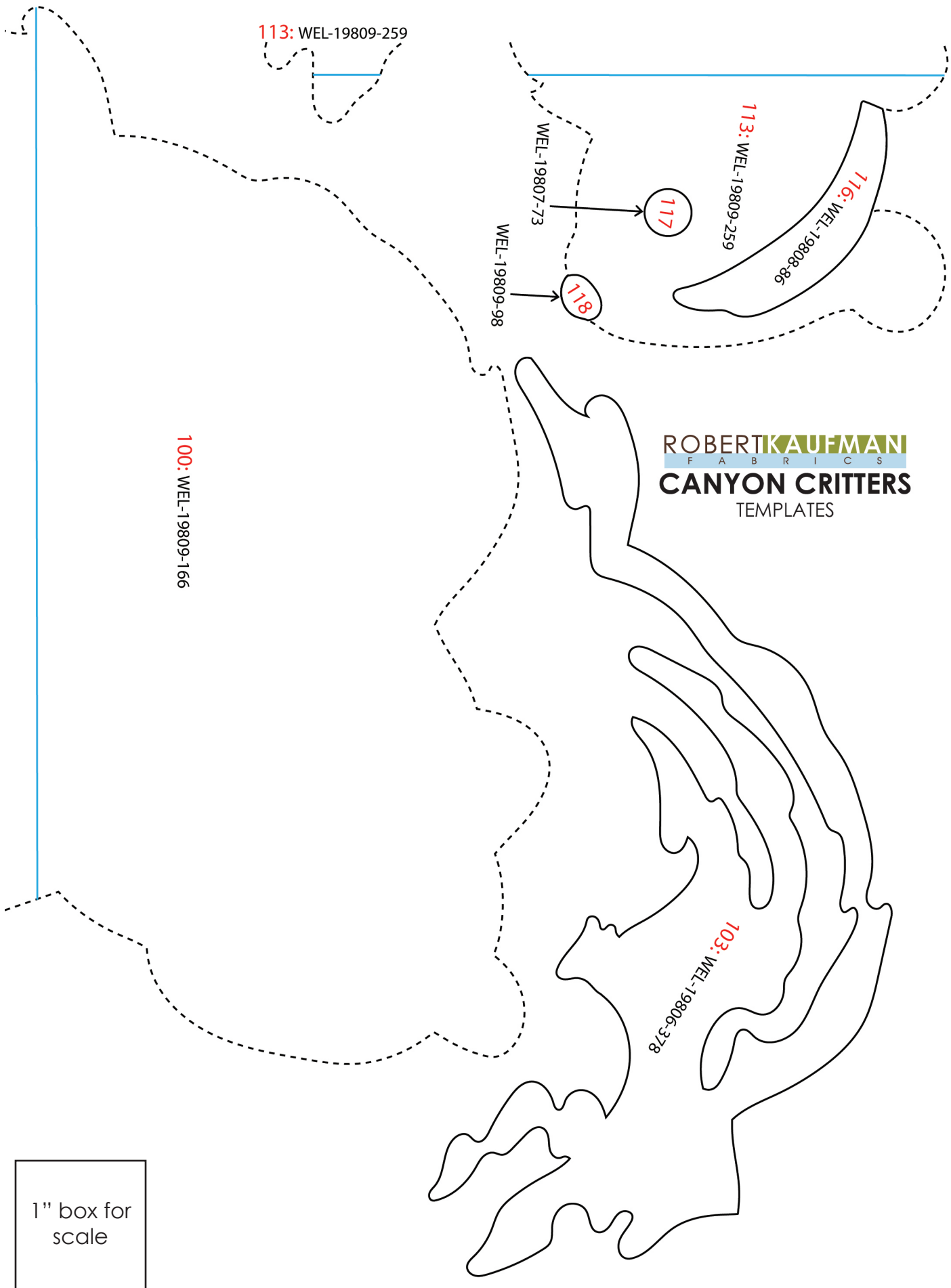

113: WEL-19809-259

113: WEL-19809-259

116: WEL-19808-86

117

WEL-19807-73

WEL-19809-98

118

100: WEL-19809-166

ROBERT KAUFMAN
F A B R I C S
CANYON CRITTERS
TEMPLATES

103: WEL-19806-378

1" box for
scale

114: WEL-19808-86

113: WEL-19809-259

1" box for
scale

1" box for
scale

