

# BOUQUET

Designed by Debbie Beaves for RK  
[www.robertkaufman.com](http://www.robertkaufman.com)

Featuring FLOWERHOUSE

*Pretty Sweet*  
by Debbie Beaves



Finished quilt measures: 60" x 74"

Quilt shown in "BLACK" colorstory.

For alternate "LIGHT" colorstory see pages 8-9.









Difficulty Rating: **Beginner**

**ROBERTKAUFMAN**  
F A B R I C S

For questions about this pattern, please email [Patterns@RobertKaufman.com](mailto:Patterns@RobertKaufman.com).

## Fabric and Supplies Needed

*Fabric amounts based on yardage that is 42" wide.*

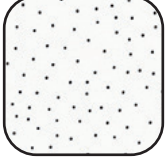
Color	Fabric	Name/SKU	Yardage	Color	Fabric	Name/SKU	Yardage
	A	FLH-20148-2 BLACK	1/2 yard		F	FLH-20151-106 BLOSSOM	1/2 yard
	B	FLH-20153-106 BLOSSOM	1/2 yard		G	FLH-20151-459 FRESH SAGE	1/8 yard
	C	FLH-20149-2 BLACK	2-1/4 yard		H	FLH-20152-107 PETAL	1/2 yard
	D	FLH-20152-2 BLACK	1/3 yard		Binding*	FLH-20151-106 BLOSSOM <i>*Also used for Fabric F</i>	1/2 yard
	E	FLH-20013-231 NIGHTFALL	1-1/4 yard	You will also need: 4 yards for backing			

Copyright 2020, Robert Kaufman  
For individual use only - Not for resale

### Notes Before You Begin

- Read through all of the instructions before beginning.
- All of the seam allowances are 1/4" unless otherwise noted.
- Press seam allowances open unless otherwise noted.
- Width of fabric (WOF) is equal to at least 42" wide.
- Right sides together has been abbreviated to RST.
- Remember to measure twice and cut once!

## Cutting Instructions

### **From Fabric A, cut:**

two 6-1/2" x WOF strips. Subcut:  
twelve 6-1/2" squares

### **From Fabric B, cut:**

ten 1-1/2" x WOF strips. Subcut:  
twenty-four 1-1/2" x 6-1/2" side block borders  
twenty-four 1-1/2" x 8-1/2" top/bottom block borders

### **From Fabric C, fussy cut:**

two 6-1/2" x 61-1/2" top/bottom outer borders  
two 6-1/2" x 74-1/2" side outer borders

### **From Fabric D, cut:**

two 5-1/4" x WOF strips. Subcut:  
twelve 5-1/4" squares. Cut each square in half along both diagonals.

### **From Fabric E, cut:**

one 12-1/2" x WOF strip. Subcut:  
sixteen 2-1/2" x 12-1/2" sashing strips  
six 2-1/2" x WOF strips. Sew together, end-to-end, and from this cut one additional  
2-1/2" x 12-1/2" sashing strip for a total of seventeen. Set the remainder aside for Border 1.  
forty-eight of Template 1  
forty-eight of Template 1-Reversed

### **From Fabric F, cut:**

three 4-7/8" x WOF strips. Subcut:  
twenty-four 4-7/8" squares. Cut each square in half once diagonally.

### **From Fabric G, cut:**

one 2-1/2" x WOF strip. Subcut:  
six 2-1/2" squares

### **From Fabric H, cut:**

six 2-1/2" x WOF strips. Sew together, end-to-end, then set aside for Border 2.

### **From the Binding Fabric, cut:**

seven 2-1/2" x WOF strips

# Assembly Instructions

**Step 1:** Sew the side B strips to the A center square. Press the seam allowances toward B (in the direction of the arrows). Sew the top/bottom B strips to A and press toward the B strips. Should measure 8-1/2" square.

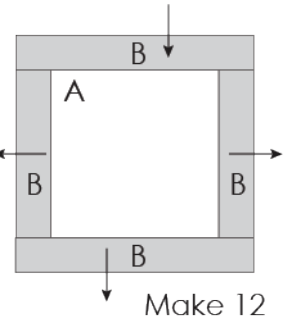

**Step 2:** Sew Fabric E, Template 1 to the Fabric D triangle. Trim points. Press toward D (in direction indicated by arrow).

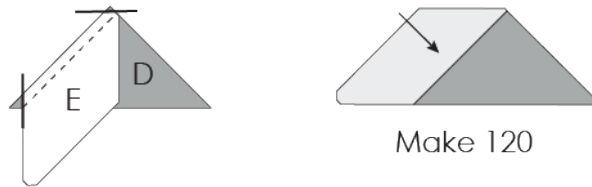

**Step 3:** Sew Fabric E, Template 1-Reversed to the step 2 unit. Trim points and press.

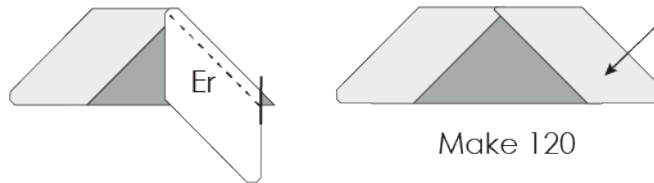

**Step 4:** Sew the D/E units to the A/B units. Press toward the A/B units.

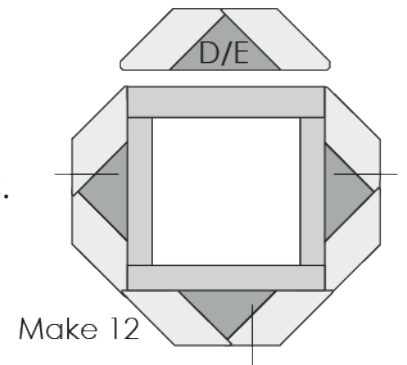

**Step 5:** Sew an F triangle to each corner of the block. Press toward F. Repeat for a total of 12 blocks. Blocks should measure 12-1/2" square.

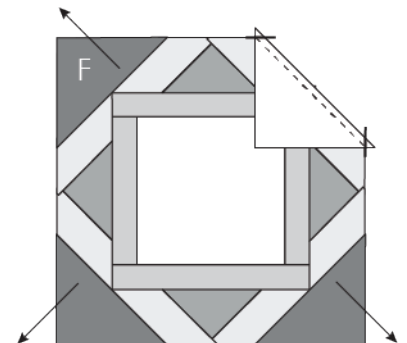

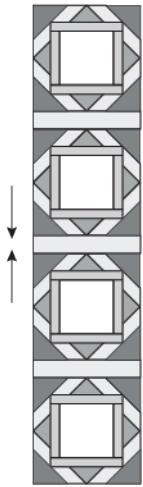

Make 3

**Step 6:** Sew the blocks into five rows of six blocks by sewing a Fabric F sashing strip between the blocks. Press the seam allowances toward the sashing. Make five block rows.

**Step 7:** Sew the remaining sashing strips and the Fabric G corner stones together into four rows (six sashing and five corner stone strips each). Press the seam allowances toward the sashing. Make four sashing rows.



Make 2

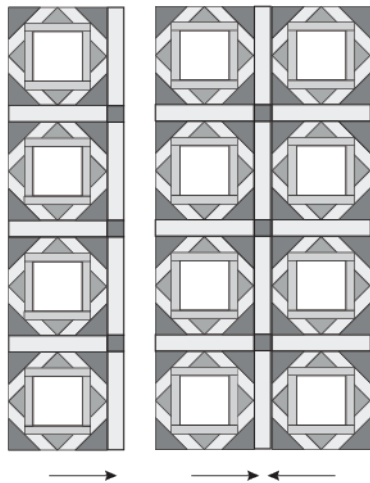

**Step 8:** Sew row to row. Press the seam allowances toward the sashing.

**Step 9:** Measure the length of the quilt through the center. Cut two Border 1 strips to this length. Sew the borders to the sides of the quilt center. Press the seam allowances toward the border strips. Measure the width of the quilt through the center. Cut two Border 1 strips to this length. Sew the borders to the top/bottom of the quilt center. Repeat this process with the Fabric H strips for Border 2

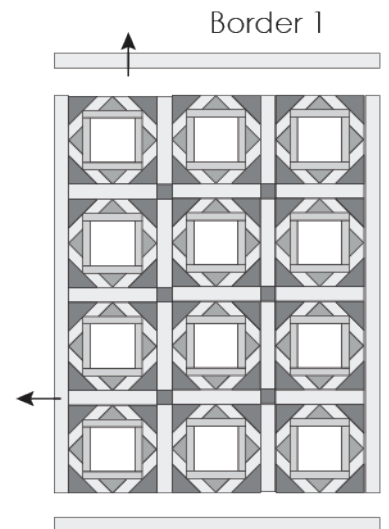

## Mitering Corners

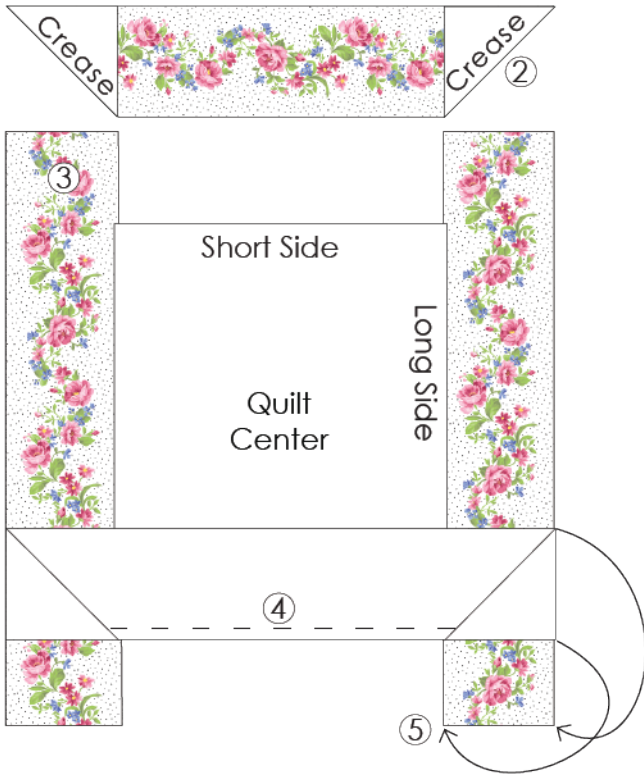

**Step 1:** Measure your quilt and make adjustments as needed to the lengths of the border strips.

**Step 2:** Press the ends of the short border strips at a 45° angle.

**Step 3:** Center and sew the two long border strips to opposite long sides of the quilt.

**Step 4:** Center and sew the short outer border strips to the short ends of the quilt. Start and stop the seams at the creases (1/4" from the ends of the pieced quilt edge).

**Step 5:** Match the short end of the border strips to each other (indicated by arrows in diagram). Pin to secure match.

**Step 6:** Sew directly on the crease. Trim excess leaving 1/4" seam allowance. Press border strips.

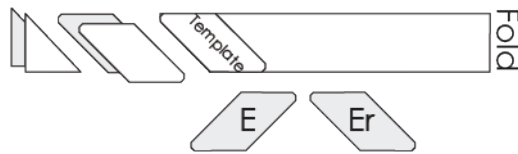
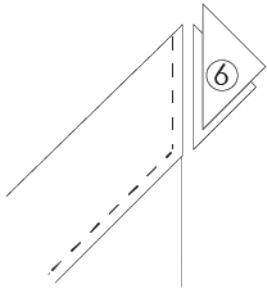

**CUTTING TIP:** Spray the section the 2-1/2" wide strips are to be cut from with Magic Sizing™ or light spray starch before cutting the strips.

Cut 2-1/2" wide x WOF strips of the natural print with each strip folded right sides together. Using the E template, cut the strips into E and Er pieces. This will yield the necessary mirror image pieces.

# Templates

Print at 100%.

Check size printed correctly using 1" box for scale prior to cutting fabric.

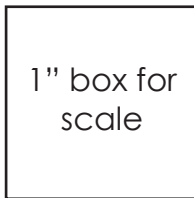
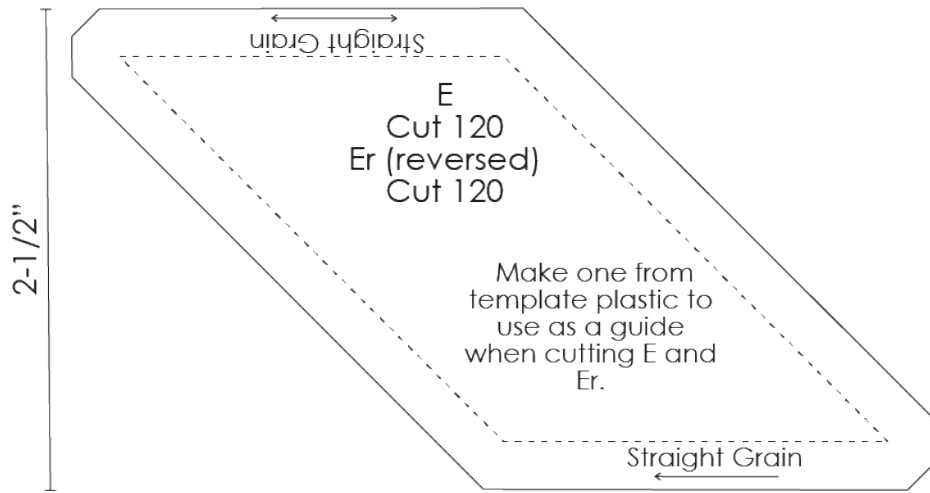

BOUQUET - Light Colorstory













# BOUQUET - Light Colorstory

## Fabric and Supplies Needed

Fabric amounts based on yardage that is 42" wide.

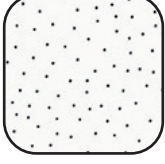
Color	Fabric	Name/SKU	Yardage	Color	Fabric	Name/SKU	Yardage
	A	FLH-20148-14 NATURAL	1/2 yard		F	FLH-20153-106 BLOSSOM	1/2 yard
	B	FLH-20151-106 BLOSSOM	1/2 yard		G	FLH-20151-459 FRESH SAGE	1/8 yard
	C	FLH-20149-14 NATURAL	2-1/4 yard		H	FLH-20152-107 PETAL	1/2 yard
	D	FLH-20153-459 FRESH SAGE	1/3 yard		Binding*	FLH-20153-106 BLOSSOM	1/2 yard
	E	FFLH-20013-231 NIGHTFALL	1-1/4 yard	<p>You will also need: 4 yards for backing</p>			
<p>Copyright 2020, Robert Kaufman For individual use only - Not for resale</p>							

This pattern may be used for personal purposes only and may not be reproduced in any form without the express permission from Robert Kaufman Fabrics. This pattern is not for resale. All patterns, unless otherwise attributed, are © Robert Kaufman Co., Inc. 2005-2020. All rights reserved.