

Floating Jewels

Designed by Free Range Quilter for RK

www.freerangequilter.com

Featuring

essex linen









Finished project measures 55" x 66"

Pattern Level: Experienced Intermediate

"I know the ropes and would like to test my skills!"

ROBERTKAUFMAN
F A B R I C S

Fabric and Supplies Needed

Color	Fabric	Name/SKU	Yardage	Color	Fabric	Name/SKU	Yardage
	A	E014-7 TOMATO	1/4 yard		D	E014-1232 MIDNIGHT	5-3/4 yards
	B	E014-192 MANGO	3/4 yard		E	E014-1336 SLATE	1-1/3 yards
	C	E014-1058 CADET	1-1/2 yards		F	E014-1470 PEWTER	3/4 yard

You will also need:
 4 yards Backing Fabric
 1/2 yard Binding Fabric
 61" x 72" Quilt Batting
 100 sheets of 8-1/2" x 14" printer or foundation
 paper

Notes Before You Begin

- Please read through all of the instructions before beginning.
- All of the seam allowances are 1/4" unless otherwise noted.
- Press seam allowances open unless otherwise noted.
- Width of fabric (WOF) is equal to at least 42" wide.
- Remember to measure twice and cut once!

Printing the Templates: Use 8-1/2" x 14" paper

- Print forty-six copies of Template A (page 7) at 100%
- Print fifty-four copies of Template B (page 8) at 100%

Tips For Accurate Paper-Piecing

- You may print the templates on plain copy paper, or use a specialty foundation paper such as Carol Doak's Foundation Paper.
- Place your fabric on the UNPRINTED side of the foundation template and sew on the printed side.
- You can transfer lines to the unprinted side of your paper by using a tracing wheel, or by folding and creasing the paper.
- Use a short stitch length (about a 1.5).
- Backstitch in the seam allowance at the beginning and end of each seam.
- Trim seam allowance to 1/4" after sewing each seam and press flat with a dry iron. This will keep your seams crisp and your templates flat.

Cutting Instructions

Fabric A

- Cut one strip 8" x WOF, then subcut
 - Six rectangles 4" x 8".
 - From the remaining strip cut six rectangles 3" x 7".

Fabric B

- Cut one strip 7" x WOF, then subcut twelve rectangles 3" x 7".
- Cut two strips 8" x WOF, then subcut twelve rectangles 4" x 8".

Fabric C

- Cut six strips 8" x WOF, then subcut seventy-two rectangles 3-1/2" x 8".

Fabric D

- Cut 18 strips 10-1/2" x WOF, then subcut:
 - Seventy-two rectangles 5-1/2" x 10-1/2"
 - One hundred-eight rectangles 3" x 10-1/2"
- Cut four strips 6-1/2" x WOF, then subcut 45° angles, as pictured, to make Inset Triangles and Corners.



Fabric E

- Cut three strips 8" x WOF, then subcut twenty-eight rectangles 4" x 8".
- Cut three strips 7" x WOF, then subcut thirty-six rectangles 3" x 7".

Fabric F

- Cut three strips 8" x WOF, then subcut thirty-six rectangles 3-1/2" x 8".

Assembly Instructions

Step 1: Paper-Piece and Assemble the Blocks

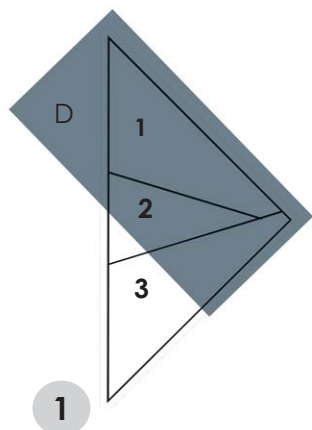

1. Using Template A, place a Fabric D 5-1/2" x 10-1/2" rectangle right side up on the **UNPRINTED** side of the template. The fabric will be entirely covering section 1 and there will be at least 1/4" of extra fabric all around the section.

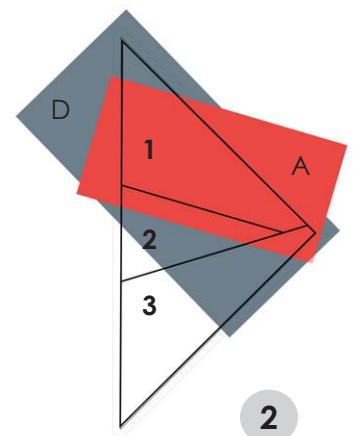

2. Place a Fabric A 4" x 8" rectangle right side down so that it is 1/4" over the line between section 1 and section 2. Be sure to position the fabric so that it will entirely cover section 2 once sewn.

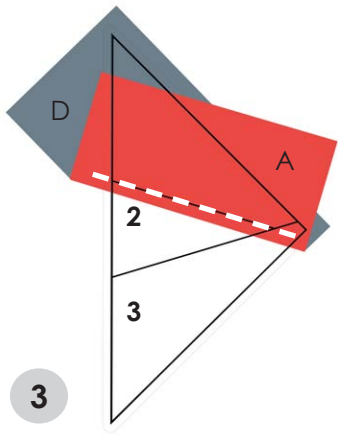

3. Sew along the line between section 1 and 2 using a small stitch. You will sew about 1/4" or so past the beginning and end of the line, and backstitch. Trim the seam allowances to 1/4".

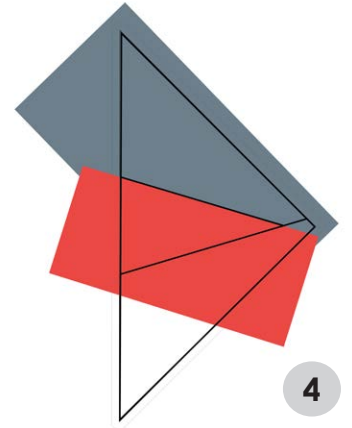

4. Flip fabric so it covers section 2 and press flat using a dry iron.

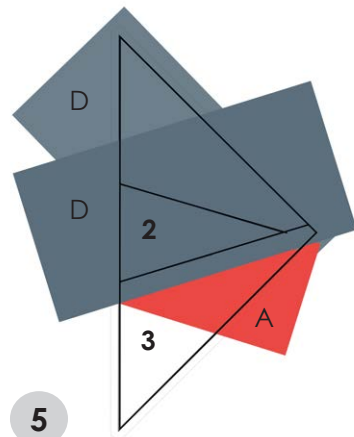

5. Place a Fabric D 5-1/2" x 10-1/2" rectangle right side down, so that it is 1/4" over the line between section 2 and 3.

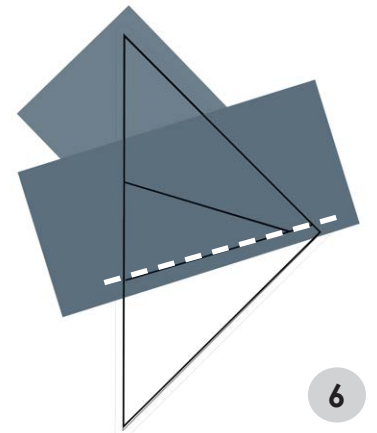

6. Sew along the line between section 2 and 3 and then trim the seam allowances to 1/4". Flip fabric so it covers section 3 and press with a dry iron.

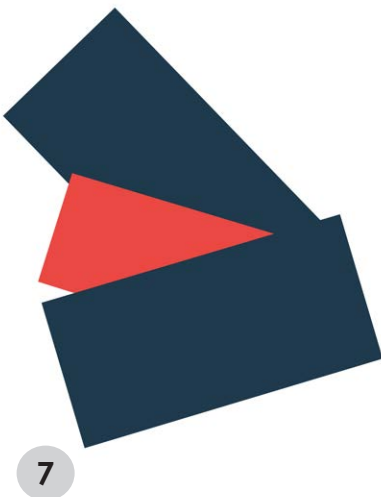

7. Your template will now look something like the image to the left.

8. Trim fabric along the seam allowance and gently remove the paper from the back.

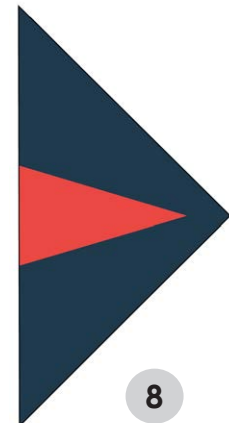

9. Repeat steps 1-8 to make a second identical triangle. Piece the two triangles together as pictured. The seams will nest together when they are matched up.

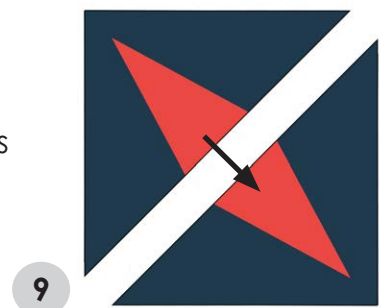

Repeat steps 1-9 to make the following blocks:

(Template B is paper-pieced the same way as Template A, but there are two extra sections.)

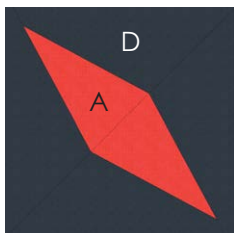

Block 1: Template A

Make 3 blocks (6 templates)

Two Fabric D 5-1/2" x 10-1/2" rectangles per template

One Fabric A 4" x 8" rectangle per template



Block 2: Template A

Make 14 blocks (28 templates)

Two Fabric D 5-1/2" x 10-1/2" rectangles per template

One Fabric E 4" x 8" rectangle per template

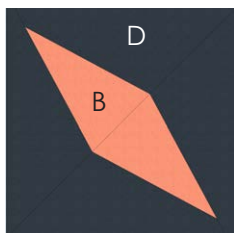

Block 3: Template A

Make 6 blocks (12 templates)

Two Fabric D 5-1/2" x 10-1/2" rectangles per template

One Fabric B 4" x 8" rectangle per template

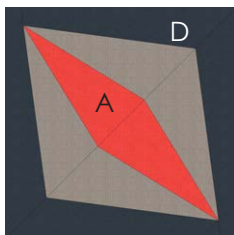

Block 4: Template B

Make 3 blocks (6 templates)

Two Fabric D 3" x 10-1/2" rectangles per template

Two Fabric F 3-1/2" x 8" rectangles per template

One Fabric A 3" x 7" rectangle per template

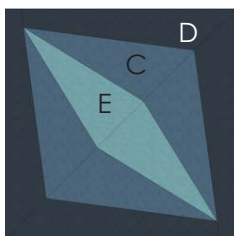

Block 5: Template B

Make 18 blocks (36 templates)

Two Fabric D 3" x 10-1/2" rectangles per template

Two Fabric C 3-1/2" x 8" rectangles per template

One Fabric E 3" x 7" rectangle per template

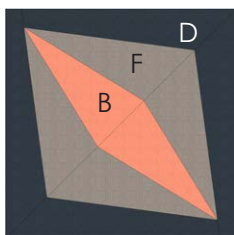

Block 6: Template B

Make 6 blocks (12 templates)

Two Fabric D 3" x 10-1/2" rectangles per template

Two Fabric F 3-1/2" x 8" rectangles per template

One Fabric B 3" x 7" rectangle per template

Step 2: Assemble the Quilt

- Sew the blocks into diagonal rows, as pictured. Each diagonal row will begin and end with a Fabric D Inset Triangle, or Corner.
- Sew the rows together, matching the seams.

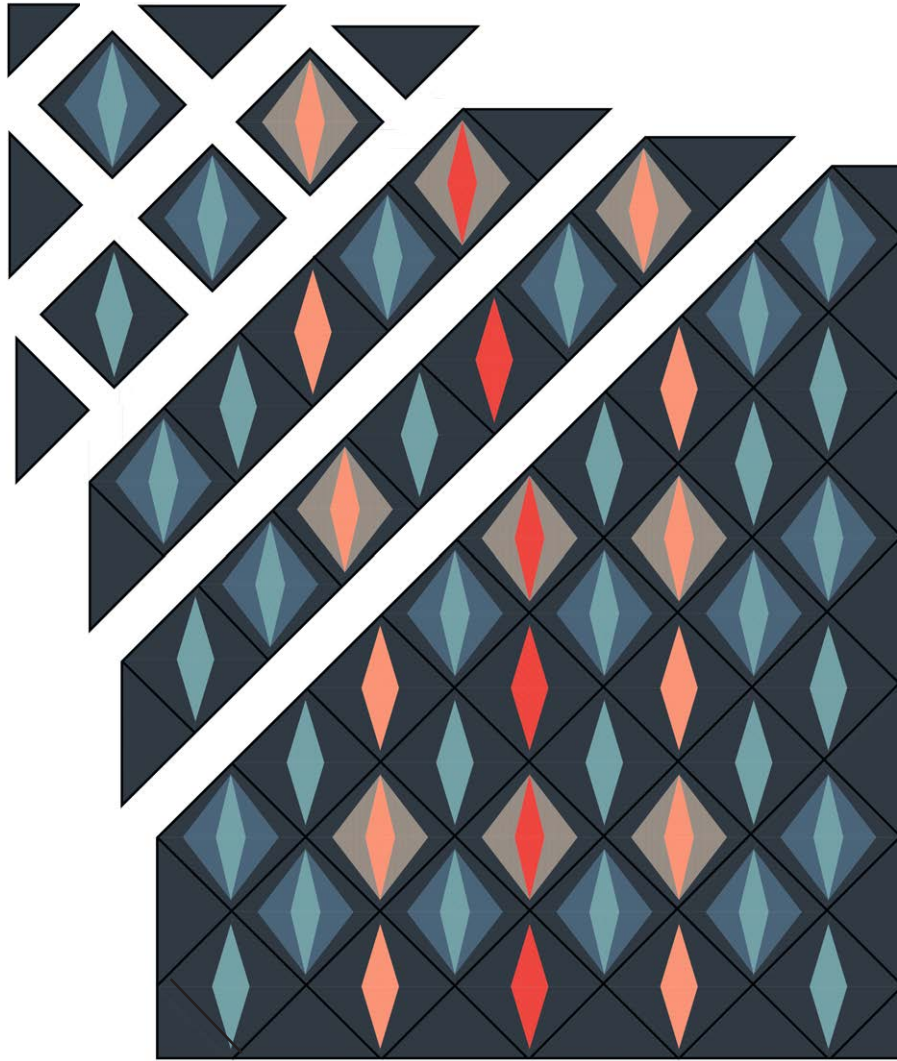

Your quilt top is complete!
Baste, quilt, bind and enjoy.

floating Jewels

Template A

Print 46 copies on 8-1/2" x 11" paper

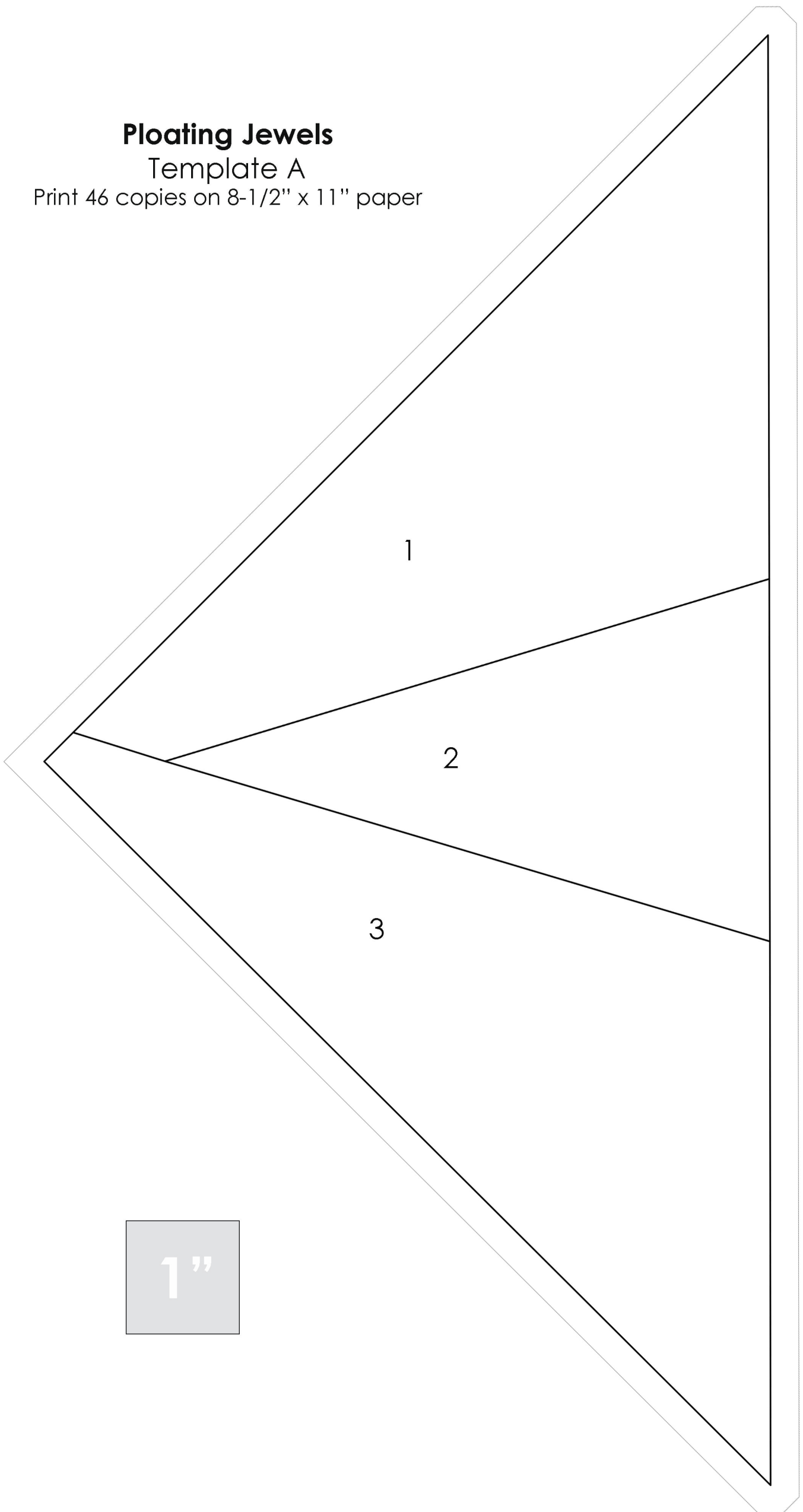

Floating Jewels

Template B

Print 54 copies on 8-1/2" x 14" paper

